



SanDisk Industrial Grade CompactFlash 5000

Product Manual

Revision 1.0

July 2007



SanDisk Corporation

Corporate Headquarters • 601 McCarthy Blvd. • Milpitas, CA 95035

Phone (408) 801-1000 • Fax (408) 801-8657

www.sandisk.com

Table of Contents

1.	Introduction.....	1
1.1	General Description.....	1
1.2	Features.....	2
1.3	Scope	3
1.4	CompactFlash Standard.....	3
1.5	PCMCIA Standard	3
1.6	Related Documentation.....	3
1.7	Functional Description	3
1.7.1	Technology Independence.....	4
1.7.2	Defect and Error Management	4
1.7.3	Wear Leveling	5
1.7.4	Bad Block Management	5
1.7.5	Using Erase Sector and Write Commands	5
1.7.6	Automatic Sleep Mode.....	5
1.7.7	Power Supply Requirements	5
2.	Product Specifications	7
2.1	Formatted Capacities.....	7
2.2	System Environmental Specifications.....	7
2.3	System Power Requirements	8
2.4	System Performance	8
2.5	System Reliability	9
2.6	Physical Specifications	9
2.7	Regulatory Compliance	10
2.8	Traceability.....	10
3.	Interface Description.....	11
3.1	Physical Description	11
3.1.1	Pin Assignments and Types	11
3.2	Electrical Description	13
3.3	Electrical Specification	17
3.3.1	Input Leakage Control and Input Characteristics	17
3.3.2	Output Drive Type and Characteristics	18
3.3.3	Power Up/Power Down Timing	19
3.3.4	Common Memory Read Timing	20
3.3.5	Common and Attribute Memory Write Timing.....	21
3.3.6	Attribute Memory Read Timing Specification	22
3.3.7	Memory Timing Diagrams	22
3.3.8	I/O Read (Input) Timing Specification	23
3.3.9	I/O Write (Output) Timing Specification	24
3.3.10	True IDE Mode	25
3.4	Card Configuration	28
3.4.1	Attribute Memory Function	29
3.4.2	Configuration Option Register (Address 200h in Attribute Memory)	30

3.4.3	Card Configuration and Status Register (Address 202h in Attribute Memory)	31
3.4.4	Pin Replacement Register (Address 204h in Attribute Memory)	32
3.4.5	Socket and Copy Register (Address 206h in Attribute Memory)	32
3.5	I/O Transfer Function	33
3.5.1	Common Memory Function	33
3.6	True IDE Mode I/O Transfer Function	33
3.6.1	True IDE Mode I/O Function	33
4.	ATA Register Set and Protocol	35
4.1	I/O Primary and Secondary Address Configurations	35
4.2	Contiguous I/O Mapped Addressing	36
4.3	Memory Mapped Addressing	37
4.4	True IDE Mode Addressing	38
4.5	ATA Registers	38
4.5.1	Data Register (Address–1F0[170]; Offset 0, 8, 9)	38
4.5.2	Error Register (Address–1F1[171]; Offset 1, 0Dh Read Only) ...	39
4.5.3	Feature Register (Address–1F1[171]; Offset 1, 0Dh Write Only)	40
4.5.4	Sector Count Register (Address–1F2[172]; Offset 2)	40
4.5.5	Sector Number (LBA 7-0) Register (Address–1F3[173]; Offset 3)	40
4.5.6	Cylinder Low (LBA 15-8) Register (Address–1F4[174]; Offset 4)	40
4.5.7	Cylinder High (LBA 23-16) Register (Address–1F5[175]; Offset 5)	40
4.5.8	Drive/Head (LBA 27-24) Register (Address–1F6[176]; Offset 6)	40
4.5.9	Status & Alternate Status Registers (Address–1F7[177]&3F6[376]; Offsets 7 & Eh)	41
4.5.10	Device Control Register (Address–3F6[376]; Offset Eh)	42
4.5.11	<i>Card (Drive) Address Register (Address–3F7[377]; Offset Fh)</i> ..	42
5.	ATA Command Description	44
5.1	ATA Command Set	44
5.1.1	Check Power Mode–98H, E5H	45
5.1.2	Execute Drive Diagnostic–90H	46
5.1.3	Erase Sector(s)–C0H	46
5.1.4	Format Track–50H	47
5.1.5	Identify Device–ECH	47
5.1.6	Idle–97H, E3H	55
5.1.7	Idle Immediate–95H, E1H	55
5.1.8	Initialize Drive Parameters–91H	55
5.1.9	Read Buffer–E4H	56
5.1.10	Read DMA Command–C8H, C9H	56
5.1.11	Read Multiple–C4H	57
5.1.12	Read Long Sector–22H, 23H	58
5.1.13	Read Sector(s)–20H, 21H	58
5.1.14	Read Verify Sector(s)–40H, 41H	58
5.1.15	Recalibrate–1XH	59

5.1.16	Request Sense–03H	59
5.1.17	Seek–7XH.....	60
5.1.18	Set Features–EFH	61
5.1.19	Set Multiple Mode–C6H.....	62
5.1.20	Set Sleep Mode–99H, E6H.....	62
5.1.21	Standby–96H, E2H.....	63
5.1.22	Standby Immediate–94H, E0H.....	63
5.1.23	Translate Sector–87H.....	64
5.1.24	Wear Level–F5H	64
5.1.25	Write Buffer–E8H.....	65
5.1.26	Write DMA Command–CAH, CBH.....	65
5.1.27	Write Long Sector–32H, 33H	65
5.1.28	Write Multiple Command–C5H	66
5.1.29	Write Multiple without Erase–CDH	67
5.1.30	Write Sector(s)–30H, 31H.....	67
5.1.31	Write Sector(s) without Erase–38H.....	68
5.1.32	Write Verify Sector(s)–3CH	68
5.2	Error Posting.....	69
6.	CIS Description.....	70
	Appendix A. Ordering Information.....	86
	Appendix B. Limited Warranty	87
	Appendix C. Disclaimer of Liability.....	89

List of Tables

Table 1: Formatted Capacities	7
Table 2: Environmental Specifications.....	7
Table 3: Power Requirements:	8
Table 4: Performance:	8
Table 5: Reliability:	9
Table 6: Dimensions	9
Table 7: PC Card Memory Mode Pin Assignments	11
Table 8: PC Card I/O Mode Pin Assignments.....	12
Table 9: True IDE Mode Pin Assignments	13
Table 10: Signal Description	14
Table 11: Input Leakage Control.....	17
Table 12: Input Characteristics.....	17
Table 13: Output Drive Type.....	18
Table 14: Output Drive Characteristics	18
Table 15: Power Up/Power Down Timing	19
Table 16: Common Memory Read Timing Specification	20
Table 17: Common and Attribute Memory Write Timing Specification	21
Table 18: Attribute Memory Read Timing Specification.....	22
Table 19: I/O Read (Input) Timing Specification	24
Table 20: I/O Write Timing Specification.....	25
Table 21: Register Transfer to/from Device.....	26
Table 22: PIO Data Transfer to/from Device	27
Table 23: Registers and Memory Space Decoding	28
Table 24: Configuration Registers Decoding	29
Table 25: Attribute Memory Function	30
Table 26: Card Configurations	31
Table 27: Pin Replacement Changed Bit/Mask Bit Values.....	32
Table 28: Common Memory Function	33
Table 29: IDE Mode I/O Function	34
Table 30: Standard I/O Configurations	35
Table 31: Primary and Secondary I/O Decoding.....	35
Table 32: Contiguous I/O Decoding.....	36
Table 33: Memory Mapped Decoding	37
Table 34: True IDE Mode I/O Decoding	38

Table 35: Data Register	39
Table 36: Primary and Secondary I/O Decoding	44
Table 37: Check Power Mode	46
Table 38: Execute Drive Diagnostic.....	46
Table 39: Diagnostic Codes.....	46
Table 40: Erase Sector(s)	46
Table 41: Format Track	47
Table 42: Identify Device	47
Table 43: Identify Device Information.....	47
Table 44: Word 82 Description	52
Table 45: Word 83 Description	52
Table 46: Word 85 Description	52
Table 47: Word 86 Description	53
Table 48: Idle.....	55
Table 49: Idle Immediate.....	55
Table 50: Initialize Drive Parameters.....	56
Table 51: Read Buffer	56
Table 52: Read DMA Command.....	56
Table 53: Read DMA Command.....	57
Table 54: Read Long Sector	58
Table 55: Read Sector(s)	58
Table 56: Read Verify Sector(s).....	59
Table 57: Recalibrate.....	59
Table 58: Request Sense.....	59
Table 59: Extended Error Codes	60
Table 60: Seek	60
Table 61: Set Features	61
Table 62: Features Supported.....	61
Table 63: Set MultipleMode.....	62
Table 64: Set Multiple Mode.....	63
Table 65: Standby.....	63
Table 66: Standby Immediate.....	63
Table 67: Translate Sector.....	64
Table 68: Translate Sector Information.....	64
Table 69: Wear Level	64

Table 70: Write Buffer	65
Table 71: Write DMA Command.....	65
Table 72: Write Long Sector	66
Table 73: Write Multiple Command	66
Table 74: Write Multiple w/out Erase	67
Table 75: Write Sector(s)	67
Table 76: Write Sector(s) w/out Erase	68
Table 77: Write Verify Sectors.....	68
Table 78: Error and Status Registers	69
Table 79: Card Information Structure	70

1. Introduction

1.1 General Description

SanDisk Industrial Grade CompactFlash® 5000 (CompactFlash 5000) provides high capacity solid-state flash memory that electrically complies with the Personal Computer Memory Card International Association ATA (PC Card ATA) standard (In Japan, the applicable standards group is JEIDA).

The CompactFlash 5000 also supports a True ATA (IDE) mode that is electrically compatible with an IDE disk drive.

The original CompactFlash (CF) form factor card can be used in any system that has a CF slot, and with a Type II PCMCIA adapter can be used in any system that has a PCMCIA Type II or Type III socket.

CompactFlash 5000 uses SanDisk flash memory, designed specifically for use in mass storage applications.

In addition to the mass storage-specific flash memory chips, CompactFlash 5000 includes an on-card intelligent controller that provides a high level interface to the host computer.

This interface allows a host computer to issue commands to the memory card to read or write blocks of memory. The host addresses the card in 512 byte sectors. Each sector is protected by a powerful Error Correcting Code (ECC).

The on-card intelligent controller in the CompactFlash 5000 manages interface protocols, data storage and retrieval as well as ECC, defect handling and diagnostics, power management and clock control.

Once the card has been configured by the host, it appears to the host as a standard ATA (IDE) disk drive. Additional ATA commands have been provided to enhance system performance.

The host system can support as many cards as there are CompactFlash and PCMCIA Type II or III card slots. The original form factor CompactFlash Memory cards require a PCMCIA Type II Adapter to be used in a PCMCIA Type II or Type III socket.

Figure 1 below illustrates the block diagram of the SanDisk High Level CompactFlash card.

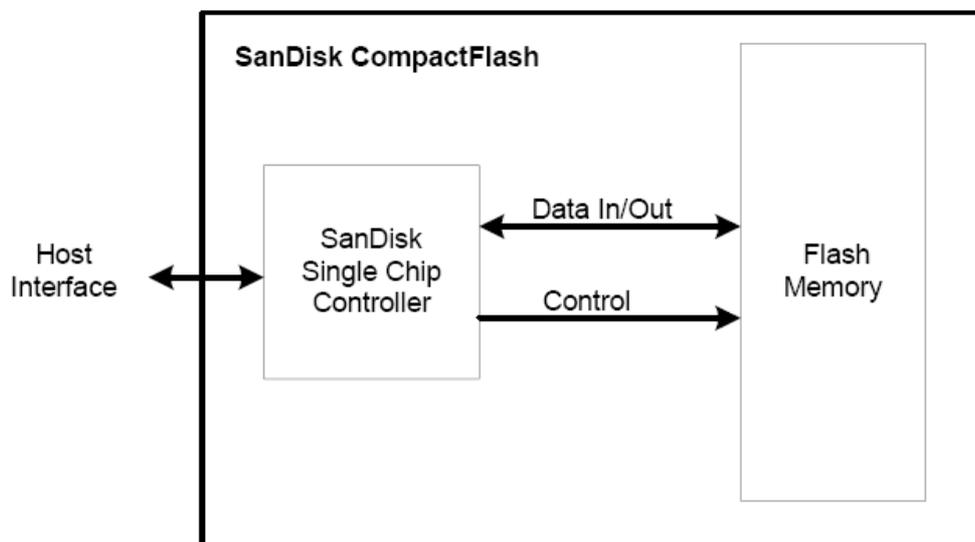

Figure 1: SanDisk High Level CompactFlash Card Block Diagram

1.2 Features

SanDisk CompactFlash 5000 provides the following system features:

- Non-volatile storage (no battery required)
- Up to 8 GB of mass storage data based on SanDisk reliable SLC flash technology
- Fixed and Removable configurations
- PC Card ATA compatible
- True IDE Mode compatible
- Low power consumption
- High performance:
Read & Write sustained performance of 30MB/sec
- Rugged – Complies with MIL-STD-810F
- Low weight
- Silent
- Low Profile
- +5 Volt or +3.3 Volt operation
- Automatic 8 bit error detection / error correction
- Supports power down commands and sleep modes
- MTBF > 4,000,000 hours
- Minimum 10,000 insertions

1.3 Scope

This document describes the key features and specifications of CompactFlash 5000, as well as the information required to interface this product to a host system.

1.4 CompactFlash Standard

SanDisk CompactFlash 5000 is fully compatible with the CompactFlash Specification 4.1 published by the CompactFlash Association.

Contact the CompactFlash Association for more information.

CompactFlash Association

P.O. Box 51537

Palo Alto, CA 94303

USA

Phone: 415-843-1220

Fax: 415-493-1871

www.compactflash.org

1.5 PCMCIA Standard

SanDisk CompactFlash 5000 is fully electrically compatible with the PCMCIA specifications listed below:

- PCMCIA PC Card Standard, 7.0, February 1999
- PCMCIA PC Card ATA Specification, 7.0, February 1999

These specifications may be obtained from:

PCMCIA

2635 N. First Street, Suite 209

San Jose, CA 95131

USA

Phone: 408-433-2273

Fax: 408-433-9558

1.6 Related Documentation

ATA operation is governed by the ATA-4 specification published by ANSI. For more information refer to the American National Standard X3.221: AT Attachment for Interface for Disk Drives.

Documentation can be ordered from IHS by calling 1-800-854-7179 or accessing their Web site: <http://global.ihs.com>

1.7 Functional Description

SanDisk CompactFlash 5000 contains a high level, intelligent subsystem as shown in the block diagram, Figure 1

This intelligent (microprocessor) subsystem provides many capabilities not found in other memory cards.

These capabilities include:

- Standard ATA register and command set (the same as that found on most magnetic disk drives).
- Host independence from details of erasing and programming flash memory.
- Sophisticated system for defect management (analogous to systems found on magnetic disk drives).
- Sophisticated system for error recovery, including a powerful error correction code (ECC).
- Power management for low power operation.
- Implementation of dynamic and static wear-leveling to extend the life of the card life.

1.7.1 Technology Independence

The 512-byte sector size of the CompactFlash 5000 is the same as that of an IDE magnetic disk drive. To write or read a sector (or multiple sectors), the host computer software simply issues a Read or Write command to the card.

This command contains the address and the number of sectors to write/read. The host software then waits for the command to be completed.

The host software does not participate in the details of how the flash memory is erased, programmed or read. This is extremely important as flash devices are expected to get more and more complex in the future. Because the CompactFlash 5000 uses an intelligent on-board controller, the host system software will not need to be changed as new flash memory evolves.

In other words, systems that support CompactFlash 5000 now will be able to access future SanDisk cards built with new flash technology without any need to update or change host software.

1.7.2 Defect and Error Management

CompactFlash 5000 contains a sophisticated defect and error management system.

This system is similar to the systems found on magnetic disk drives, and in many cases offers enhancements.

If necessary, the card will rewrite data from a defective sector to a good sector. This is completely transparent to the host and does not consume any user data space.

The CompactFlash 5000 soft error rate specification is much better than the magnetic disk drive specification.

In the extremely rare case that a read error does occur, CompactFlash 5000 has innovative algorithms to recover the data by using hardware on-the-fly 8 bit Error Detection Code/Error Correction Code (EDC/ECC), based on a BCH algorithm.

These defect and error management systems, coupled with the solid state construction, give SanDisk CompactFlash 5000 unparalleled reliability.

1.7.3 Wear Leveling

Wear-leveling is an inherent part of the erase pooling functionality of SanDisk CompactFlash 5000 using NAND memory.

The CF WEAR LEVEL command is supported as a NOP operation to maintain backward compatibility with existing software utilities. Advanced features of dynamic and static wear-leveling and automatic block management are used to ensure high data reliability and maximize flash life expectancy.

1.7.4 Bad Block Management

Bad blocks are occasionally created during the life cycle of a flash component, in a phenomenon called dynamic bad-block accumulation. These bad blocks must be dynamically marked and replaced dynamically to prevent read/write failures.

When a bad block is detected, the embedded Bad Block Mapping algorithm maps out the block, which will no longer be used for storage.

1.7.5 Using Erase Sector and Write Commands

SanDisk CompactFlash 5000 supports the CF ERASE SECTOR and WRITE WITHOUT ERASE commands.

In some applications, write operations may be faster if the addresses being written are first erased with the ERASE SECTOR command. WRITE WITHOUT ERASE behaves as a normal write command and no performance gain results from its use.

1.7.6 Automatic Sleep Mode

A unique feature of the SanDisk CompactFlash 5000 is automatic entrance and exit from sleep mode.

If no further commands are received within 5 msec of completion of a command, the card will enter sleep mode to conserve power.

The host does not have to take any action for this to happen. In most systems, the CompactFlash 5000 is in sleep mode except when being accessed by the host, thus conserving power.

The waiting period from command completion to entering sleep mode is adjustable.

When the host is ready to access the card and the card is in sleep mode, any command issued to it will cause the card to exit sleep mode and respond.

The host does not have to follow the ATA protocol of issuing a reset first. It may do this if desired, but it is not necessary. Not issuing the reset improves reduces overhead and improves performance, but this must be done only for the SanDisk products as other ATA products may not support this feature.

1.7.7 Power Supply Requirements

This is a dual voltage product, meaning that it will operate at a voltage range of 3.30 volts \pm 5% or 5.00 volts \pm 10%.

Per the PCMCIA specification Section 2.1.1, the host system must apply 0 volts in order to change a voltage range.

The procedure of providing 0 volts to the card is also necessary if the host system applies an input voltage of more than 15% less than the voltage range, i.e. less than 4.25 volts for the 5.00-volt range and less than 2.75 volts for the 3.30 volt range.

2. Product Specifications

For all the following specifications, values are defined at ambient temperature and nominal supply voltage unless otherwise stated.

2.1 Formatted Capacities

Table 1: shows the formatted capacities for the CompactFlash 5000:

Table 1: Formatted Capacities

Capacity [MB]	Capacity (formatted in bytes)	Sectors/Card (Max. LBA+1)	No. of Heads	No. of Sectors/Track	No. of Cylinders
512	512,483,328	1,000,944	16	63	993
1024	1,024,966,656	2,001,888	16	63	1,986
2048	2,048,901,120	4,001,760	16	63	3,970
4096	4,110,188,544	8,027,712	16	63	7,964
8192	8,195,604,480	16,007,040	16	63	15,880

2.2 System Environmental Specifications

Table 2 lists the environmental specifications, including temperature, humidity, noise level, vibration, shock and altitude.

Table 2: Environmental Specifications

Specification	Parameters
Temperature	Operating (Commercial): 0° C to 70° C Operating (Industrial): -25° C to 85° C Non-operating: -40° C to 95° C
Humidity	8% to 95% non-condensing
Noise Level	0 dB
Vibration	15 G peak to peak maximum
Shock	2,000 G maximum
Altitude (relative to sea level)	80,000 ft. maximum
ESD	Contact discharge: Up to 4KV Air discharge: Up to 8KV

2.3 System Power Requirements

All values quoted in Table 3 are typical at 25° C and nominal supply voltage unless otherwise stated.

Sleep mode currently is specified under the condition that all card inputs are static CMOS levels and in a "Not Busy" operating state.

Table 3: Power Requirements:

DC Input Voltage (Vcc) 100 mV max. ripple (p-p)	3.3V +/- 10%	5V +/- 10%
Sleep	300 μ A	500 μ A
Read	75 mA	100 mA
Write	75 mA	100 mA
Read/Write Peak	100 mA	100 mA

2.4 System Performance

All performance timings in Table 4 assume the CompactFlash 5000 controller is in the default (i.e. fastest) mode.

Table 4: Performance:

Specification	Parameters
Start-up times	
Sleep to Write	2.5 ms maximum
Sleep to Read	20 ms maximum
Reset to Ready	50 ms typical; 400 ms maximum
Maximum Performance	
Sequential Read	30.0 MB/sec
Sequential Write	30.0 MB/sec
Random Read – Single Sector Read	1 MB/sec
Random Write – Single Sector Write	30 KB/sec
Host compatibility	
uDMA 0-4	Up to 66 MB/sec
PIO 0-6	Up to 25 MB/sec
MultiWord DMA 0-4	Up to 25 MB/sec

Note: The Sleep to Write and Sleep to Read times represent the time it takes the CompactFlash 5000 to exit sleep mode upon any command issued by the host until the card starts reading or writing. CompactFlash 5000 does not require a reset to exit sleep mode.

2.5 System Reliability

Table 5: Reliability:

Specification	Parameters
MTBF (@ 25 C)	> 4M Hours
Preventative Maintenance	None
Data Reliability	<1 non-recoverable error in 10 ¹⁴ bits read <1 erroneous correction in 10 ²⁰ bits read

2.6 Physical Specifications

Refer to Table 6: and Figure 2: CompactFlash 5000 Dimensions for the physical specifications and dimensions of CompactFlash 5000.

CompactFlash 5000 is in the form factor of CF Type I.

Table 6: Dimensions

Dimension	Parameters
Weight	11.4 g (.40 oz) typical, 14.2 g (.50 oz) maximum
Length	36.40 ± 0.15 mm (1.433 ± .006 in)
Width	42.80 ± 0.10 mm (1.685 ± .004 in)
Thickness	3.3 mm ± 0.10 mm (.130 ± .004 in) (Excluding Lip)

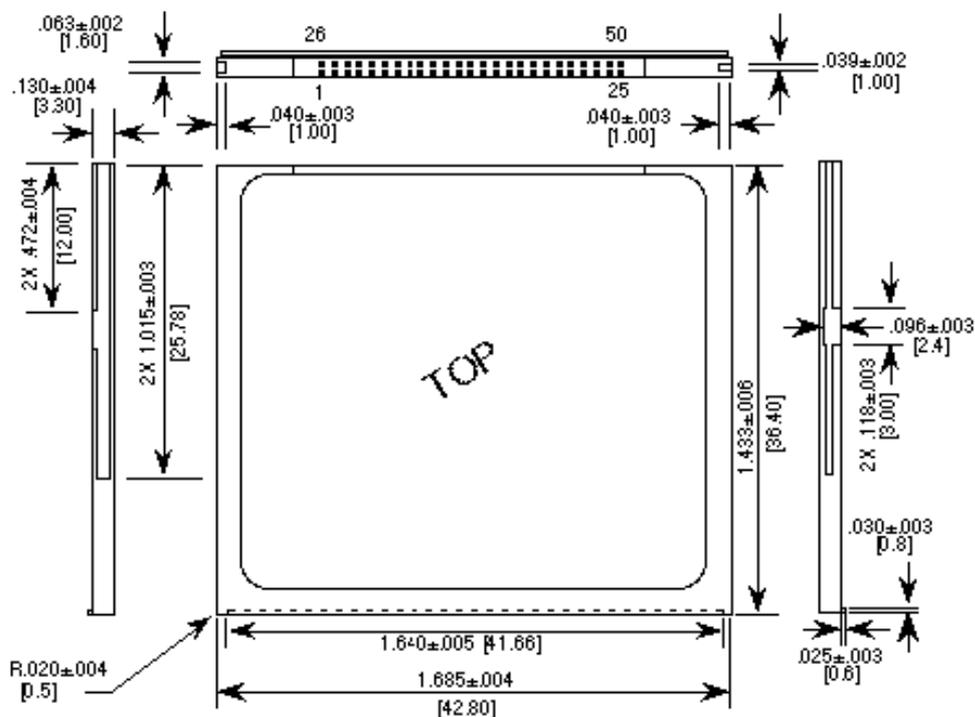

Figure 2: CompactFlash 5000 Dimensions

2.7 Regulatory Compliance

CompactFlash 5000 complies with the following:

- CF 4.1 Compliance
- RoHS (6 Materials)
- FCC Class B for Information Technology
- CE EN 55022/55024
- MIL-STD-810F

2.8 Traceability

3. Interface Description

3.1 Physical Description

The host connects to SanDisk CompactFlash Memory cards using a standard 50-pin connector with two rows of 25 female contacts, each on 50 mil (1.27 mm) centers.

3.1.1 Pin Assignments and Types

Table 7 lists the signal/pin assignments. Low active signals have a "-" prefix. Pin types are Input, Output or Input/Output. Sections 3.3.1 and 3.3.2 define the DC characteristics for all input and output type structures.

Table 7: PC Card Memory Mode Pin Assignments

Pin No.	SignalName	Pin Type	I/O Type	Pin No.	SignalName	Pin Type	I/O Type
1	GND	–	Ground	26	-CD1	O	Ground
2	D03	I/O	I1Z,OZ3	27	D11	I/O	I1Z,OZ3
3	D04	I/O	I1Z,OZ3	28	D12	I/O	I1Z,OZ3
4	D05	I/O	I1Z,OZ3	29	D13	I/O	I1Z,OZ3
5	D06	I/O	I1Z,OZ3	30	D14	I/O	I1Z,OZ3
6	D07	I/O	I1Z,OZ3	31	D15	I/O	I1Z,OZ3
7	-CE1	I	I3U	32	-CE2	I	I3U
8	A10	I	I1Z	33	-VS1	O	Ground
9	-OE	I	I3U	34	-IORD	I	I3U
10	A09	I	I1Z	35	-IOWR	I	I3U
11	A08	I	I1Z	36	-WE	I	I3U
12	A07	I	I1Z	37	RDY/BSY	O	OT1
13	VCC	–	Power	38	VCC	–	Power
14	A06	I	I1Z	39	-CSEL	I	I2Z
15	A05	I	I1Z	40	-VS2	O	OPEN
16	A04	I	I1Z	41	RESET	I	I2Z
17	A03	I	I1Z	42	-WAIT	O	OT1
18	A02	I	I1Z	43	-INPACK	O	OT1
19	A01	I	I1Z	44	-REG	I	I3U
20	A00	I	I1Z	45	BVD2	I/O	I1U,OT1
21	D00	I/O	I1Z,OZ3	46	BVD1	I/O	I1U,OT1
22	D01	I/O	I1Z,OZ3	47	D08	I/O	I1Z,OZ3
23	D02	I/O	I1Z,OZ3	48	D09	I/O	I1Z,OZ3
24	WP	O	OT3	49	D10	I/O	I1Z,OZ3
25	-CD2	O	Ground	50	GND	–	Ground

Table 8 lists PC Card I/O Pin Assignments.

Table 8: PC Card I/O Mode Pin Assignments

Pin No.	SignalName	Pin Type	I/O Type	Pin No.	SignalName	Pin Type	I/O Type
1	GND	–	Ground	26	-CD1	O	Ground
2	D03	I/O	I1Z,OZ3	27	D11	I/O	I1Z,OZ3
3	D04	I/O	I1Z,OZ3	28	D12	I/O	I1Z,OZ3
4	D05	I/O	I1Z,OZ3	29	D13	I/O	I1Z,OZ3
5	D06	I/O	I1Z,OZ3	30	D14	I/O	I1Z,OZ3
6	D07	I/O	I1Z,OZ3	31	D15	I/O	I1Z,OZ3
7	-CE1	I	I3U	32	-CE2	I	I3U
8	A10	I	I1Z	33	-VS1	O	Ground
9	-OE	I	I3U	34	-IORD	I	I3U
10	A09	I	I1Z	35	-IOWR	I	I3U
11	A08	I	I1Z	36	-WE	I	I3U
12	A07	I	I1Z	37	-IREQ	O	OT1
13	VCC	–	Power	38	VCC	–	Power
14	A06	I	I1Z	39	-CSEL	I	I2Z
15	A05	I	I1Z	40	-VS2	O	OPEN
16	A04	I	I1Z	41	RESET	I	I2Z
17	A03	I	I1Z	42	-WAIT	O	OT1
18	A02	I	I1Z	43	-INPACK	O	OT1
19	A01	I	I1Z	44	-REG	I	I3U
20	A00	I	I1Z	45	-SPKR	I/O	I1U,OT1
21	D00	I/O	I1Z,OZ3	46	-STSCHG	I/O	I1U,OT1
22	D01	I/O	I1Z,OZ3	47	D08	I/O	I1Z,OZ3
23	D02	I/O	I1Z,OZ3	48	D09	I/O	I1Z,OZ3
24	-IOIS16	O	OT3	49	D10	I/O	I1Z,OZ3
25	-CD2	O	Ground	50	GND	–	Ground

Table 9 lists true IDE Mode Pin Assignments.

Table 9: True IDE Mode Pin Assignments

Pin No.	SignalName	Pin Type	I/O Type	Pin No	SignalName	Pin Type	I/O Type
1	GND	–	Ground	26	-CD1	O	Ground
2	D03	I/O	I1Z,OZ3	27	D11	I/O	I1Z,OZ3
3	D04	I/O	I1Z,OZ3	28	D12	I/O	I1Z,OZ3
4	D05	I/O	I1Z,OZ3	29	D13	I/O	I1Z,OZ3
5	D06	I/O	I1Z,OZ3	30	D14	I/O	I1Z,OZ3
6	D07	I/O	I1Z,OZ3	31	D15	I/O	I1Z,OZ3
7	-CS0	I	I3Z	32	-CS1	I	I3Z
8	A10	I	I1Z	33	-VS1	O	Ground
9	-ATA SEL	I	I3U	34	-IORD	I	I3Z
10	A09	I	I1Z	35	-IOWR	I	I3Z
11	A08	I	I1Z	36	-WE	I	I3U
12	A07	I	I1Z	37	INTRQ	O	OZ1
13	VCC	–	Power	38	VCC	–	Power
14	A06	I	I1Z	39	-CSEL	I	I2U
15	A05	I	I1Z	40	-VS2	O	OPEN
16	A04	I	I1Z	41	RESET	I	I2Z
17	A03	I	I1Z	42	IORDY	O	OT1
18	A02	I	I1Z	43	-DMARQ	O	OZ1
19	A01	I	I1Z	44	-DMACK	I	I3U
20	A00	I	I1Z	45	-DASP	I/O	I1U,ON1
21	D00	I/O	I1Z,OZ3	46	-PDIAG	I/O	I1U,ON1
22	D01	I/O	I1Z,OZ3	47	D08	I/O	I1Z,OZ3
23	D02	I/O	I1Z,OZ3	48	D09	I/O	I1Z,OZ3
24	-IOCS16	O	ON3	49	D10	I/O	I1Z,OZ3
25	-CD2	O	Ground	50	GND	–	Ground

3.2 Electrical Description

The CompactFlash Memory Card Series is optimized for operation with hosts that support the PCMCIA I/O interface standard conforming to the PC Card ATA specification. However, the card may also be configured to operate in systems that support only the memory interface standard. The CompactFlash card configuration is controlled using the standard PCMCIA configuration registers starting at address 200h in the Attribute Memory space of the card.

Table 10: Signal Description describes the I/O signals. Signals whose source is the host are designated as inputs, while signals whose source is the card are outputs. SanDisk CompactFlash Memory Card logic levels conform to those specified in Section 3.3 of the PCMCIA Release 2.1 Specification.

Note: The Sleep to Write and Sleep to Read times represent the time it takes the CompactFlash 5000 to exit sleep mode upon any command issued by the host until the card starts reading or writing. CompactFlash 5000 does not require a reset to exit sleep mode.

Table 10: Signal Description

Signal Name	Dir.	Pin	Description
A10-A0 (PC Card Memory Mode) (PC Card I/O Mode) A2-A0 (True IDE Mode) A10-A3 (True IDE Mode)	I I	8, 10, 11, 12, 14, 15, 16, 17, 18, 19, 20 18, 19, 20	These address lines, along with the -REG signal, are used to select the following: I/O and memory-mapped port address registers within the card, a byte in the card's information structure and its configuration control and status registers. In True IDE Mode only A[2:0] is used to select one of eight registers in the Task File. In True IDE Mode these remaining address lines should be grounded by the host.
BVD1 (PC Card Memory Mode) -STSCHG (PC Card I/O Mode) -PDIAG (True IDE Mode)	I/O	46	This signal is asserted high as the BVD1 signal since a battery is not used with this product. The Status Changed signal is asserted low to alert the host to changes in the RDY/-BSY and Write Protect states, while the I/O interface is configured. Its use is controlled by the Card Config. and Status Register. In True IDE Mode, this input/output is the Pass Diagnostic signal in the master/slave handshake protocol.
BVD2 (PC Card Memory Mode) -SPKR (PC Card I/O Mode) -DASP (True IDE Mode)	I/O	45	This output line is always driven to a high state in Memory Mode since a battery is not required for this product, as well as in I/O Mode, since this product does not support the audio function. In True IDE Mode, this input/output is the Disk Active/Slave Present signal in the master/ slave handshake protocol.
-CD1, -CD2 (PC Card Memory Mode) (PC Card I/O Mode) (True IDE Mode)	O	26, 25	These Card Detect pins are connected to ground on the card. The host uses these pins to determine if the card is fully inserted into its socket.
-CE1, -CE2 (PC Card Memory Mode) (PC Card I/O Mode) -CS0, -CS1 (True IDE Mode)	I	7, 32	The Card Enable input signals are used both to select the card and to indicate to the card whether a byte or a word operation is being performed. -CE2 always accesses the odd byte of the word. -CE1 accesses either the even or the odd byte of the word, depending on A0 and -CE2. A multiplexing scheme based on A0, -CE1, -CE2 allows 8 bit hosts to access all data on D0-D7. In True IDE Mode, -CS0 is the chip select for the Task File registers, while -CS1 is used to select the Alternate Status Register and the Device Control Register.
-CSEL (PC Card Memory Mode) (PC Card I/O Mode)	I	39	This signal is not used for PC Card Memory Mode or PC Card I/O Mode.
-CSEL (True IDE Mode)			This internally pulled up signal is used to configure the device as a master or slave when configured in True IDE Mode. When this pin is grounded, the device is configured as a master. When the pin is open, this device is configured as a slave.
D15-D00 (PC Card Memory Mode) (PC Card I/O Mode) D15-D00 (True IDE Mode)	I/O	31, 30, 29, 28, 27, 49, 48, 47, 6, 5, 4, 3, 2, 23, 22, 21	These lines carry the data, commands and status information between the host and the controller. D00 is the LSB of the word's even byte; D08 is the LSB of the word's odd byte. In True IDE Mode, all Task File operations occur in byte mode on the low order bus D00D07 while all data transfers are 16 bits using D00-D15.
GND (PC Card Memory Mode) (PC Card I/O Mode)		1, 50	Ground.

(True IDE Mode)			
-INPACK (PC Card Memory Mode) -INPACK (PC Card I/O Mode) -DMARQ (True IDE Mode)	O	43	This signal is not used in this mode. The card asserts the Input Acknowledge signal when it is selected and responding to an I/O read cycle at the address that is on the address bus. The host uses this signal to control the enable of any input data buffers between the card and the CPU. This signal is used for DMA data transfers between host and device and is asserted by the device when it is ready to transfer data to or from the host. The direction of data transfer is controlled by DIOR- and DIOW-. This signal is used in a handshake manner with DMACK- (i.e., the device waits until the host asserts DMACK- before negating DMARQ, and reasserting DMARQ if there is more data to transfer).
-IORD (PC Card Memory Mode) -IORD (PC Card I/O Mode) (True IDE Mode)	I	34	This signal is not used in this mode. This is an I/O read strobe generated by the host. This signal gates I/O data onto the bus from the card when the card is configured to use the I/O interface.
-IOWR (PC Card Memory Mode)	I	35	This signal is not used in this mode.
-IOWR (PC Card I/O Mode) (True IDE Mode)			The I/O write strobe pulse is used to clock I/O data on the Card Data bus into the card controller registers when the card is configured to use the I/O interface. The clocking will occur on the negative to positive edge of the signal (trailing edge).
-OE (PC Card Memory Mode) -OE (PC Card I/O Mode) -ATA SEL (True IDE Mode)	I	9	This is an output enable strobe generated by the host interface. It is used to read data from the card in Memory Mode and to read the CIS and configuration registers. In PC Card I/O Mode, this signal is used to read the CIS and configuration registers. To enable True IDE Mode this input should be grounded by the host.
RDY/-BSY (PC Card Memory Mode) -IREQ (PC Card I/O Mode) INTRQ (True IDE Mode)	O	37	In Memory Mode, this signal is set high when the card is ready to accept a new data transfer operation and held low when the card is busy. The host memory card socket must provide a pull-up resistor. At power up and at reset the RDY/-BSY signal is held low (busy) until the card has completed its power up or reset function. No access of any type should be made to the card during this time. The RDY/-BSY signal is held high (disabled from being busy) whenever the following condition is true: the card has been powered up with +RESET continuously disconnected or asserted. I/O Operation—After the card has been configured for I/O operation, this signal is used as an interrupt request. This line is strobed low to generate a pulse mode interrupt or held low for a level mode interrupt. In True IDE Mode, this signal is the active high Interrupt Request to the host.
-REG (PC Card Memory Mode) -REG (PC Card I/O Mode)	I	44	This Attribute Memory Select signal is used during memory cycles to distinguish between Common Memory and Register (Attribute) Memory accesses: High for common memory and low for attribute memory. The signal must also be active (low) during I/O cycles when the I/O address is on the bus.

-DMACK (True IDE Mode)			The host uses this signal in response to DMARQ to initiate DMA transfers. NOTE: This signal may be negated by the host to suspend the DMS transfer in process. For Multiword DMA transfers, the device may negate DMARQ with the tL specified time once the DMACK- is asserted and reasserted again at a later time to resume DMA operation. Alternatively, if the device is able to continue the data transfer, the device may leave DMARQ asserted and wait for the host to reassert DMACK-.
RESET (PC Card Memory Mode) (PC Card I/O Mode) - RESET (True IDE Mode)	I	41	When the pin is high, this signal resets the card. The card is reset only at power-up if this pin is left high or open from power-up. The card is also reset when the Soft Reset bit in the Card Configuration Option Register is set. In True IDE Mode this input pin is the active low hardware reset from the host.
VCC (PC Card Memory Mode) (PC Card I/O Mode) (True IDE Mode)		13, 38	+5V, +3.3V power.
-VS1 -VS2 (PC Card Memory Mode) (PC Card I/O Mode) (True IDE Mode)	O	33, 40	Voltage Sense Signals. -VS1 is grounded so that the CompactFlash Card CIS can be read at 3.3 volts and VS2 is open and reserved by PCMCIA for a secondary voltage.
-WAIT (PC Card Memory Mode) -WAIT (PC Card I/O Mode) IORDY (True IDE Mode)	O	42	SanDisk CompactFlash Memory cards do not assert the -WAIT signal. SanDisk CompactFlash Memory cards, except when in UDMA modes, do not assert an IORDY signal.
-WE (PC Card Memory Mode) -WE (PC Card I/O Mode) -WE (True IDE Mode)	I	36	This is a host-driven signal used for strobing memory write data to the registers of the card when it is configured in the Memory Interface Mode. It is also used for writing the configuration registers. In PC Card I/O Mode, this signal is used for writing the configuration registers. In True IDE Mode this input signal is not used and should be connected to VCC by the host.
WP (PC Card Memory Mode)	O	24	Memory Mode—The CompactFlash Card does not have a write-protect switch. This signal is held low after the completion of the reset initialization sequence.
-IOIS16 (PC Card I/O Mode) - IOCS16 (True IDE Mode)			I/O Operation—When the card is configured for I/O Operation, pin 24 is used for the -I/O Selected is 16 Bit Port (-IOIS16) function. A low signal indicates that a 16-bit or odd-byte only operation can be performed at the addressed port. This output signal is asserted low when this device is expecting a word data transfer cycle.

3.3 Electrical Specification

All CompactFlash Memory Card D.C. characteristics are defined as follows:

Typical conditions unless otherwise stated:

- VCC = 5V +/- 10%
- VCC = 3.3V +/- 5%
- Ta = 0 ° C to 60 ° C

Absolute Maximum conditions:

- VCC = -0.3V min. to 6.5V max.
- V* = 0.5V min. to VCC + 0.5V max.
- *Voltage on any pin except VCC with respect to GND.

3.3.1 Input Leakage Control and Input Characteristics

In Table 11: Input Leakage Control "x" refers to the characteristics described in Table 12. For example—"I1U" indicates a pull-up resistor with a Type 1 input characteristic.

Table 11: Input Leakage Control

Type	Parameter	Symbol	Conditions	MIN	MAX	Unit
IxZ	Input Leakage Current	IL	Vih=VCC/Vil=GND	-1	1	uA
IxU	Pull Up Resistor	RPU1	VCC=5.0V	50k	500k	Ohm
IxD	Pull Down Resistor	RPD1	VCC=5.0V	50k	500k	Ohm

Note: The minimum pull-up resistor leakage current meets the PCMCIA specification of 10k ohms, but is intentionally higher in the CompactFlash Memory Card Series product to reduce power use.

Table 12 defines the input characteristics of the parameters.

Table 12: Input Characteristics

Type	Parameter	Symbol	Min.	Typ.	Max.	Min.	Typ.	Max.	Unit
			VCC = 3.3V			VCC = 5.0V			
1	Input Voltage CMOS	Vih	2.4			4.0			V
		Vil			0.6			0.8	
2	Input Voltage CMOS	Vih	1.5			2.0			V
		Vil			0.6			0.8	
3	Input Voltage CMOS Schmitt Trigger	Vth		1.8			2.8		V
		Vtl		1.0			2.0		

3.3.2 Output Drive Type and Characteristics

In Table 13 "x" refers to the characteristics described in Table 14. For example—"OT3" refers to Totem pole output with a Type 3 output drive characteristic.

Table 13: Output Drive Type

Type	Output Type	Valid Conditions
OTx	Totempole	Ioh & Iol
OZx	Tri-state N-P Channel	Ioh & Iol
OPx	P-Channel Only	Ioh only
ONx	N-Channel Only	Ioh Only

Table 14: Output Drive Characteristics

Type	Parameter	Symbol	Conditions	Min.	Typ.	Max.	Unit
1	Output Voltage	Voh	Ioh = -4 mA	VCC			V
				-0.8V			
		Vol	Iol = 4 mA			Gnd	
						+0.4V	
2	Output Voltage	Voh	Ioh = -8 mA	VCC			V
				-0.8V			
		Vol	Iol = 8 mA			Gnd	
						+0.4V	
3	Output Voltage	Voh	Ioh = -8 mA	VCC			V
				-0.8V			
		Vol	Iol = 8 mA			Gnd	
						+0.4V	
X	Tri-State Leakage Current	Ioz	Vol = Gnd Voh = VCC	-10		10	uA

3.3.3 Power Up/Down Timing

The timing specification in Table 15 was defined to permit peripheral cards to perform power-up initialization.

Table 15: Power Up/Power Down Timing

Item	Symbol	Condition	Value		
			Min.	Max.	Unit
CE Signal Level ^a	Vi (CE)	$0V < V_{CC} < 2.0V$	0	V_{IMAX}	V
		$2.0V < V_{CC} < V_{IH}$	$< V_{CC} - 0.1$	V_{IMAX}	
		$< V_{IH} < V_{CC}$	V_{IH}	V_{IMAX}	
CE Setup Time	$T_{SU}(V_{CC})$	---	20	---	ms
CE Setup Time	$T_{SU}(RESET)$	---	20	---	ms
CE Recover Time	$T_{REC}(V_{CC})$	---	0.001	---	ms
V_{CC} Rising Time ^b	t_{pr}	10%-->90% of $(V_{CC} + 5\%)$	0.1	300	ms
V_{CC} Falling Time ^b	t_{pf}	90% of $(V_{CC} + 5\%)$ -->10%	3.0	300	ms
Reset Width	$T_W(RESET)$	---	10	---	μs
	$T_h(Hi-z\ Reset)$	---	1	---	ms
	$T_s(Hi-z\ Reset)$	---	0	---	ms

- a. V_{IMAX} means Absolute Maximum Voltage for Input in the period of $0V < V_{CC} < 2.0V$, Vi (CE) is only $0V \sim V_{IMAX}$.
- b. The t_{pr} and t_{pf} are defined as "linear waveform" in the period of 10% to 90% or vice-versa. Even if the waveform is not "linear waveform," its rising and falling time must be met by this specification.

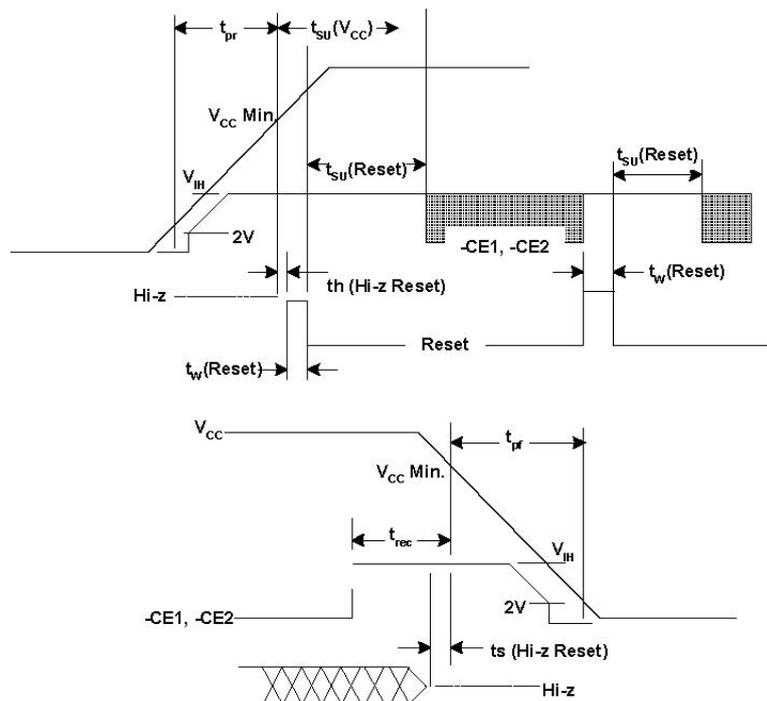

Figure 3: Power Up/Power Down Timing for Systems supporting RESET

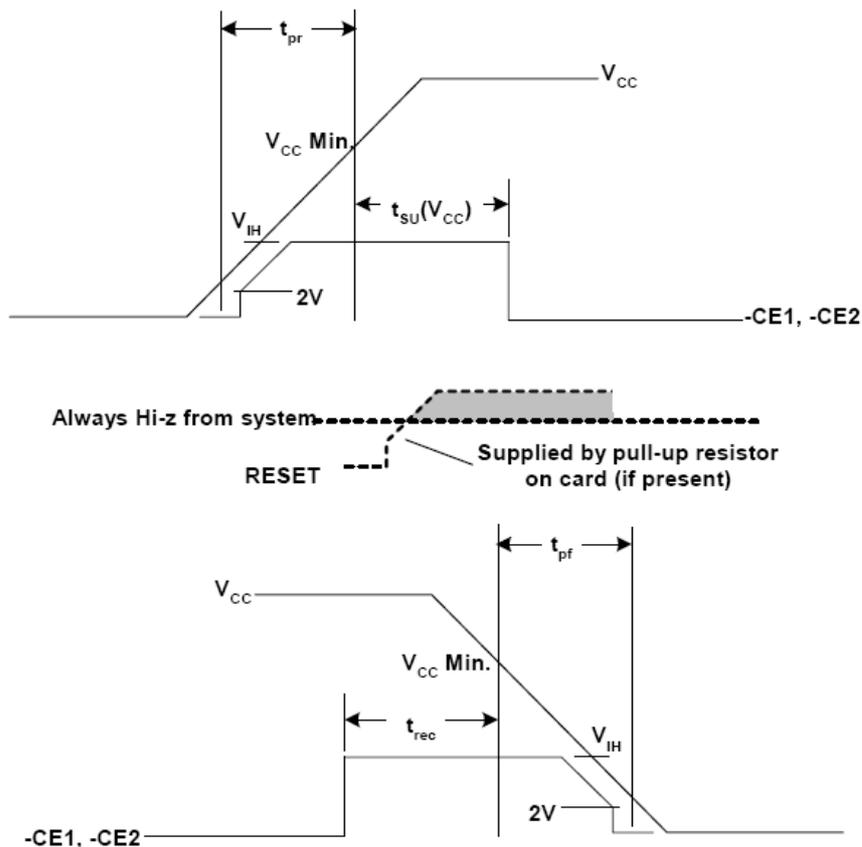

Figure 4: Power Up/ Down Timing for Systems not supporting RESET

3.3.4 Common Memory Read Timing

Table 16 contains common memory read timing specifications for all types of memory.

Note: All timings measured at the CompactFlash Memory Card. Skews and delays from the system driver/receiver to the card must be accounted for by the system.

Table 16: Common Memory Read Timing Specification

Speed Version Item	Symbol	IEEE Symbol	100 ns	
			Min.	Max.
Read Cycle Time	t_c (R)	t_{AVAV}	100	---
Address Access Time ^a	t_a (A)	t_{AVQV}	---	100
Card Enable Access Time	t_a (CE)	t_{ELQV}	---	100
Output Enable Access Time	t_a (OE)	t_{GLQV}	---	50
Output Disable Time from -OE	t_{dis} (OE)	t_{GHQZ}	---	50
Output Disable Time from -CE	t_{dis} (CE)	t_{EHQZ}	---	50
Output Enable Time from -CE	t_{en} (CE)	t_{ELQNZ}	5	---
Output Enable Time from -OE	t_{en} (OE)	t_{GLQNZ}	5	---
Data Valid from Add Change ^a	t_v (A)	t_{AXQX}	0	---
Address Setup Time	t_{su} (A)	t_{AVGL}	10	---

Table 16 (continued)

Speed Version Item	Symbol	IEEE Symbol	100 ns	
			Min.	Max.
Address Hold Time	$t_h(A)$	t_{GHAX}	15	---
Card Enable Setup Time	$t_{su}(CE)$	t_{ELGL}	0	---
Card Enable Hold Time	$t_h(CE)$	t_{GHEH}	15	---

a. The -REG signal timing is identical to address signal timing

3.3.5 Common and Attribute Memory Write Timing

The write timing specifications for Common and Attribute memory are the same.

All timings measured at the CompactFlash Memory Card. Skews and delays from the system driver/receiver to the card must be accounted for by the system

Note: SanDisk CompactFlash Memory cards do not assert the -WAIT signal.

Table 17: Common and Attribute Memory Write Timing Specification

Speed Version	Symbol	IEEE Symbol	100 ns	
			Min.	Max.
Write Cycle Time	$t_c(W)$	t_{AVAV}	100	---
Write Pulse Width	$t_w(WE)$	t_{WLWH}	60	---
Address Setup Time ^a	$t_{su}(A)$	t_{AVWL}	10	---
Address Setup Time for -WE ^a	$t_{su}(A-WEH)$	t_{AVWH}	70	---
Card Enable Setup Time for -WE	$t_{su}(CE-WEH)$	t_{ELWH}	70	---
Data Setup Time form -WE	$t_{su}(D-WEH)$	t_{DVWH}	40	---
Data Hold Time	$t_h(D)$	t_{WMDX}	15	---
Write Recover Time	$t_{rec}(WE)$	t_{WMAX}	15	---
Output Disable Time from -WE	$t_{dis}(WE)$	t_{WLQZ}	---	50
Output Disable Time from -OE	$t_{dis}(OE)$	t_{GHQZ}	---	50
Output Enable Time from -WE	$t_{en}(WE)$	t_{WHQNZ}	5	---
Output Enable Time from -OE	$t_{en}(OE)$	t_{GLQNZ}	5	---
Output Enable Setup from -WE	$t_{su}(OE-WE)$	t_{GHWL}	10	---
Output Enable Hold from -WE	$t_h(OE-WE)$	t_{WHGL}	10	---
Card Enable Setup Time	$t_{su}(CE)$	t_{ELWL}	0	---
Card Enable Hold Time	$t_h(CE)$	t_{GHEH}	15	---

a. The -REG signal timing is identical to address signal timing.

3.3.6 Attribute Memory Read Timing Specification

Table 18 contains common memory write timing specifications for all types of memory.

Note: SanDisk CompactFlash Memory cards do not assert the -WAIT signal.

Table 18: Attribute Memory Read Timing Specification

Speed Version Item	Symbol	IEEE Symbol	300 ns	
			Min.	Max.
Read Cycle Time	$t_c(R)$	t_{AVAV}	300	---
Address Access Time ^a	$t_a(A)$	t_{AVQV}	---	300
Card Enable Access Time	$t_a(CE)$	t_{ELQV}	---	300
Output Enable Access Time	$t_a(OE)$	t_{GLQV}	---	150
Output Disable Time from -OE	$t_{dis}(OE)$	t_{GHQZ}	---	100
Output Enable Time from -OE	$t_{en}(OE)$	t_{GLQNZ}	5	---
Data Valid from Add Change ^a	$t_v(A)$	t_{AXQX}	0	---
Address Setup Time	$t_{su}(A)$	t_{AVGL}	30	---
Address Hold Time	$t_h(A)$	t_{GHAX}	20	---
Card Enable Setup Time	$t_{su}(CE)$	t_{ELGL}	0	---
Card Enable Hold Time	$t_h(CE)$	t_{GHEH}	20	---

a. The -REG signal timing is identical to address signal timing

3.3.7 Memory Timing Diagrams

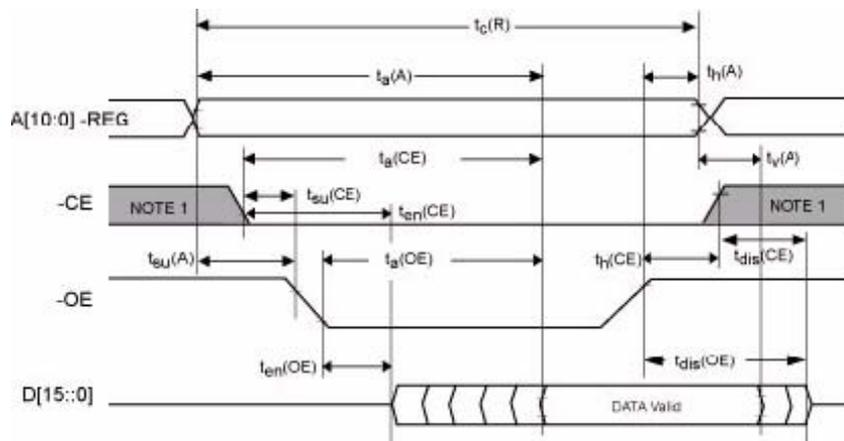

Figure 5: Common and Attribute Memory Read Timing Diagram

Note: Shaded areas may be high or low.

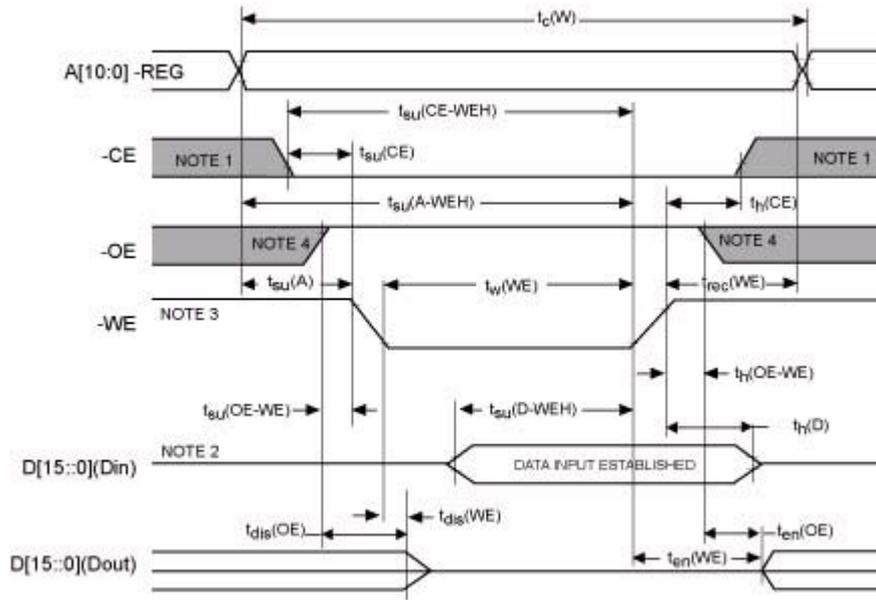

Figure 6: Common and Attribute Memory Write Timing Diagram

- Notes:
- 1) Shaded areas may be high or low.
 - 2) When the data I/O pins are in the output state, no signals shall be applied to the data pins (D[15:0]) by the host system
 - 3) May be high or low for write timing, but restrictions on -OE from previous figures apply.
 - 4) SanDisk CompactFlash Memory Cards do not assert the -WAIT signal.

3.3.8 I/O Read (Input) Timing Specification

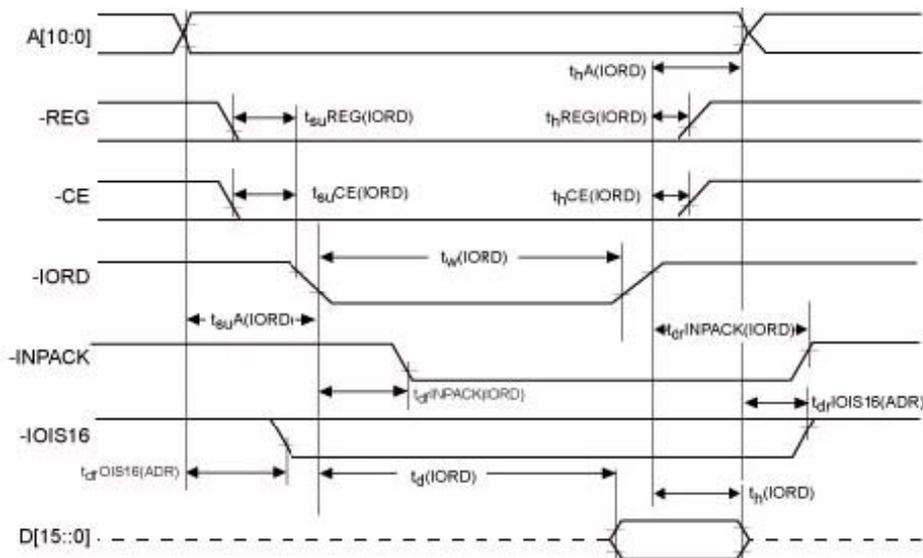

Figure 7: I/O Read Timing Diagram

- Notes:
- 1) All timings are measured at the CompactFlash Memory Card.
 - 2) Skews and delays from the host system driver/receiver to the card must be accounted for by the system design.

3) D[15::0] signifies data provided by the card to the host system.

Table 19 contains the read input timing specifications.

Note: SanDisk CompactFlash Memory cards do not assert a -WAIT signal.

Table 19: I/O Read (Input) Timing Specification

Item	Symbol	IEEE Symbol	Min. (ns)	Max. (ns)
Data Delay after -IORD	td (IORD)	tIGLQV		100
Data Hold following -IORD	th (IORD)	tIGHQX	0	
-IORD Width Time	tw (IORD)	tIGLIGH	165	
Address Setup before -IORD	tsuA(IORD)	tAVIGL	70	
Address Hold following -IORD	thA(IORD)	tIGHAX	20	
-CE Setup before -IORD	tsuCE(IORD)	tELIGL	5	
-CE Hold following -IORD	thCE(IORD)	tIGHEH	20	
-REG Setup before -IORD	tsuREG(IORD)	tRGLIGL	5	
-REG Hold following -IORD	thREG(IORD)	tIGHRGH	0	
-INPACK Delay falling from -IORD	tdfINPACK(IORD)	tIGLIAL	0	45 ^a
-INPACK Delay rising from -IORD	tdrINPACK(IORD)	tIGHIAH		45 ^a
-IOIS16 Delay falling from Address	tdfIOIS16(ADR)	tAVISL		35 ^a
-IOIS16 Delay rising from Address	tdrIOIS16(ADR)	tAVISH		35 ^a

a The maximum load on -INPACK and -IOIS16 is 1 LSTTL with 50 pF total load.

3.3.9 I/O Write (Output) Timing Specification

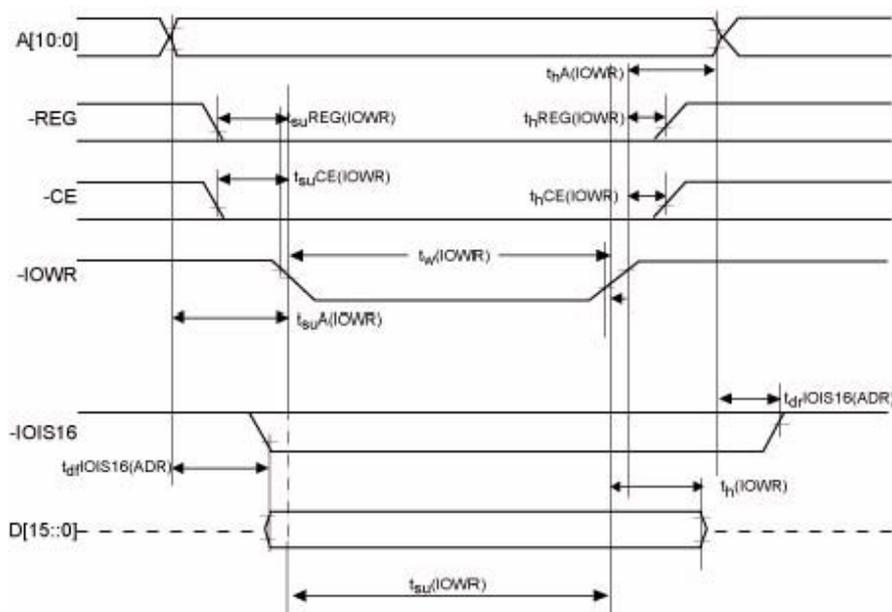

Figure 8: I/O Write Timing Diagram

- Notes: 1) All timings are measured at the CompactFlash Memory Card.
 2) Skews and delays from the host system driver/ receiver to the CompactFlash Memory Card must be accounted for by the system design.

- 3) D[15::0] signifies data provided by the host system to the CompactFlash Memory Card.

Table 20 contains the specification information related to the I/O Write Timing Diagram.

Table 20: I/O Write Timing Specification

Item	Symbol	IEEE Symbol	Min. (ns)	Max. (ns)
Data Setup before -IOWR	tsu (IOWR)	tDVIWL	60	
Data Hold following -IOWR	th (IOWR)	tWHDX	30	
-IOWR Width Time	tw (IOWR)	tWLIWH	165	
Address Setup before -IOWR	tsuA(IOWR)	tAVIWL	70	
Address Hold following -IOWR	thA(IOWR)	tIWHAX	20	
-CE Setup before -IOWR	tsuCE(IOWR)	tELIWL	5	
-CE Hold following -IOWR	thCE(IOWR)	tIWHEH	20	
-REG Setup before -IOWR	tsuREG(IOWR)	tRGLIWL	5	
-REG Hold following -IOWR	thREG(IOWR)	tIWHRGH	0	
-IOIS16 Delay falling from Address	tdfIOIS16(ADR)	tAVISL		35 ^a
-IOIS16 Delay rising from -IORD	tdr- IOIS16(ADR)	tAVISH		35
-IOIS16 Delay falling from Address	tdfIOIS16(ADR)	tAVISL		35
-IOIS16 Delay rising from Address	tdrIOIS16(ADR)	tAVISH		35

- a The maximum load on -IOIS16 is 1 LSTTL with 50 pF total load.

3.3.10 True IDE Mode

The following sections provide valuable information on the True IDE mode.

De-skewing

The host will provide cable de-skewing for all signals originating from the device. The device will provide cable de-skewing for all signals originating from the host.

All timing values and diagrams are shown and measured at the connector of the selected device.

Transfer Timing

The minimum cycle time supported by devices in PIO Mode 3, 4 and Multiword DMA Mode 1, 2 respectively will always be greater than or equal to the minimum cycle time defined by the associated mode (e.g., a device supporting PIO Mode 4 timing will not report a value less than 120 ns, the minimum cycle time defined for PIO mode 4 timings).

Register Transfers

Figure 9 defines the relationships between the interface signals for register transfers. For PIO Modes 3 and above, the minimum value of t_0 is specified by Word 68 in the IDENTIFY DEVICE parameter list. Table 22 defines the minimum value that will be placed in Word 68. In Figure 9 all signals are shown with the asserted condition facing the top of the page. The negated condition is shown towards the bottom of the page relative to the asserted condition.

Note: SanDisk CompactFlash Memory cards do not assert an -IORDY signal.

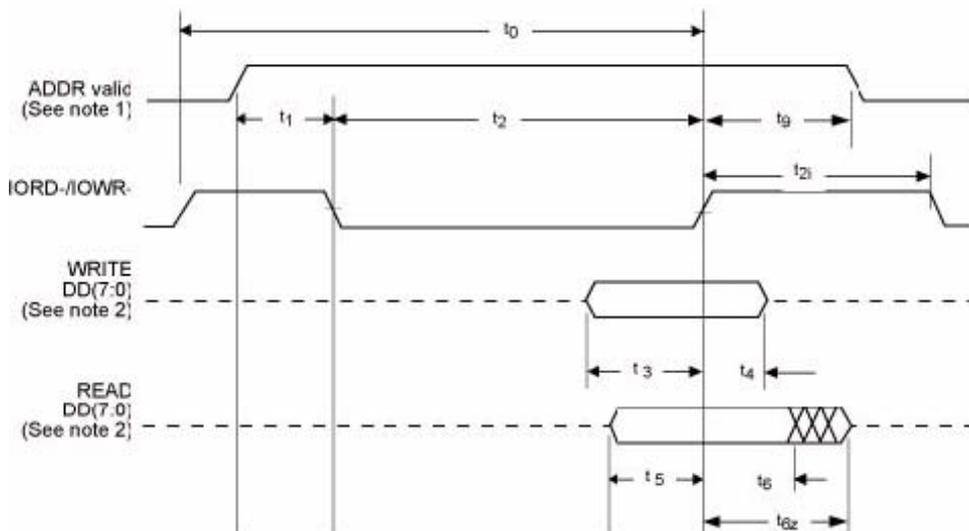

Figure 9: Register Transfer to/from Device

- Notes: 1) Device address consists of signals -CS0, -CS1 and -DA(2:0).
- 2) Data consists of DD(7:0).

Table 21: Register Transfer to/from Device

	PIO Timing Parameters	Mode 4 (ns)
t0 a	Cycle time (min.)	120
t1	Address valid to IORD-/IOWR- setup (min.)	25
t2 a	IORD-/IOWR- pulse width 8-bit (min.)	70
t2i a	IORD-/IOWR- recovery time (min.)	25
t3	IOWR- data setup (min.)	20
t4	IOWR- data hold (min.)	10
t5	IORD- data setup (min.)	20
t6	IORD- data hold (min.)	5
t6z b	IORD- data tri-state (max.)	30
t9	IORD-/IOWR- to address valid hold (min.)	10

* t0 is the minimum total cycle time, t2 is the minimum command active time, and t2i is the minimum command recovery time or command inactive time. The actual cycle time equals the sum of the actual command active time and the actual command inactive time. The three timing requirements of t0, t2, and t2i shall be met. The minimum total cycle time requirements are greater than the sum of t2 and t2i. This means a host implementation may lengthen either or both t2 or t2i to ensure that t0 is equal to or greater than the value reported in the devices IDENTIFY DEVICE data. A device implementation shall support any legal host implementation.

b. This parameter specifies the time from the negation edge of /IORD to the time that the data bus is no longer driven by the device (tri-state).

PIO Data Transfers

Figure 10 defines the relationships between the interface signals for PIO data transfers. For PIO Modes 3 and above the minimum value of t_0 is specified by Word 68 in the IDENTIFY DEVICE parameter list. Table 22 defines the minimum value that will be placed in Word 68.

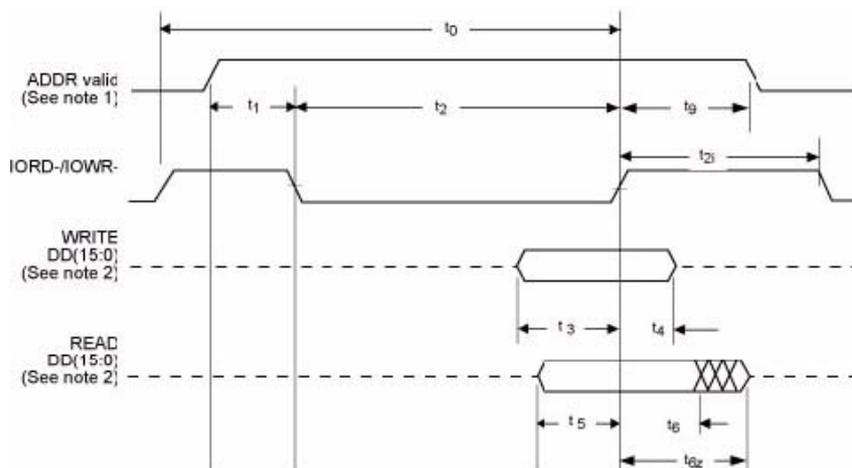

Figure 10: PIO Data Transfer to/from Device

- Notes: 1) Device address consists of signals -CS0, -CS1 and -DA(2:0).
- 2) Data consists of DD(15:0).

The PIO data transfer parameters are defined in Table 22: PIO Data Transfer to/from Device.

Note: SanDisk CompactFlash Memory cards do not assert an -IORDY signal.

Table 22: PIO Data Transfer to/from Device

	PIO Timing Parameters	Mode 0 (ns)	Mode 1 (ns)	Mode 2 (ns)	Mode 3 (ns)	Mode 4 (ns)
t0 a	Cycle time (min.)	600	383	240	180	120
t1	Address valid to IORD-/IOWR- setup (min.)	70	50	30	30	25
t2 a	IORD-/IOWR- pulse width 16-bit (min.)	165	125	100	80	70
t2ia	IORD-/IOWR- recovery time (min.)				70	25
t3	IOWR- data setup (min.)	60	45	30	30	20
t4	IOWR- data hold (min.)	30	20	15	10	10
t5	IORD- data setup (min.)	50	35	20	20	20
t6	IORD- data hold (min.)	5	5	5	5	5
t6a b	IORD- data tri-state (max.)	30	30	30	30	30
t9	IORD-/IOWR- to address valid hold (min.)	20	15	10	10	10

- a. t_0 is the minimum total cycle time, t_2 is the minimum command active time, and t_{2i} is the minimum command recovery time or command inactive time. The actual cycle time equals the sum of the actual command active time and the actual command inactive time. The three timing requirements of t_0 , t_2 , and t_{2i} shall be met. The minimum total cycle time requirements are greater than the sum of t_2 and t_{2i} . This means a host

implementation may lengthen either or both t2 or t2i to ensure that t0 is equal to or greater than the value reported in the devices IDENTIFY DEVICE data. A device implementation shall support any legal host implementation.

- b This parameter specifies the time from the negation edge of /IORD to the time that the data bus is no longer driven by the device (tri-state).

3.4 Card Configuration

SanDisk CompactFlash Memory cards are identified by appropriate information in the Card Information Structure (CIS). The configuration registers are used to coordinate the I/O spaces and the interrupt level of cards that are located in the system.

In addition, these registers provide a method for accessing status information about the card that may be used to arbitrate between multiple interrupt sources on the same interrupt level, or to replace status information that appears on dedicated pins in memory cards that have alternate use in I/O cards.

Table 23: Registers and Memory Space Decoding

- CE2 1	- CE1 1	- REG X	- OE X	- WE X	A10 X	A9 X	A8A4 XX	A3 X	A2 X	A1 X	A0 X	Selected Space Standby
X	0	0	0	1	X	1	XX	X	X	X	0	Configuration Registers Read
1	0	1	0	1	X	X	XX	X	X	X	X	Common Memory Read (8-bit D7-D0)
0	1	1	0	1	X	X	XX	X	X	X	X	Common Memory Read (8-bit D15-D8)
0	0	1	0	1	X	X	XX	X	X	X	0	Common Memory Read (16-bit D15-D0)
X	0	0	1	0	X	1	XX	X	X	X	0	Configuration Registers Write
1	0	1	1	0	X	X	XX	X	X	X	X	Common Memory Write (8bit D7-D0)
0	1	1	1	0	X	X	XX	X	X	X	X	Common Memory Write (8bit D15-D8)
0	0	1	1	0	X	X	XX	X	X	X	0	Common Memory Write (16-bit D15-D0)
X	0	0	0	1	0	0	XX	X	X	X	0	Card Info Structure Read
1	0	0	1	0	0	0	XX	X	X	X	0	Invalid Access (CIS Write)
1	0	0	0	1	X	X	XX	X	X	X	1	Invalid Access (Odd Attribute Read)
1	0	0	1	0	X	X	XX	X	X	X	1	Invalid Access (Odd Attribute Write)
0	1	0	0	1	X	X	XX	X	X	X	X	Invalid Access (Odd Attribute Read)
0	1	0	1	0	X	X	XX	X	X	X	X	Invalid Access (Odd Attribute Write)

Note: The location of the card configuration registers should always be read from the CIS since these locations may vary in future products. No writes should be performed to the card attribute memory, except to the

card configuration register addresses. All other attribute memory locations are reserved.

Decoding for the configuration registers is defined in Table 24: Configuration Registers Decoding..

Table 24: Configuration Registers Decoding

-CE2 X	-CE1 0	-REG 0	-OE 0	-WE 1	A10 0	A9 1	A8A4 00	A3 0	A2 0	A1 0	A0 0	Selected Register Configuration Option Read
X	0	0	1	0	0	1	00	0	0	0	0	Configuration Option Write
X	0	0	0	1	0	1	00	0	0	1	0	Card Status Read
X	0	0	1	0	0	1	00	0	0	1	0	Card Status Write
X	0	0	0	1	0	1	00	0	1	0	0	Pin Replacement Read
X	0	0	1	0	0	1	00	0	1	0	0	Pin Replacement Write
X	0	0	0	1	0	1	00	0	1	1	0	Socket and Copy Read
X	0	0	1	0	0	1	00	0	1	1	0	Socket and Copy Write

3.4.1 Attribute Memory Function

The CompactFlash Memory Card identification and configuration information is stored in the Attribute Memory, which is limited to 8-bit wide accesses only at even addresses. The card configuration registers are also located in the Attribute Memory.

For the Attribute Memory Read function, signals -REG and -OE must be active and -WE inactive during the cycle. As in the Main Memory Read functions, the signals -CE1 and -CE2 control the even-byte and odd-byte addresses, but only the even-byte data is valid during Attribute Memory access. Refer to

Table 25: Attribute Memory Function for signal states and bus validity for the Attribute Memory function.

Note: The -CE signal or both the -OE and -WE signals must be de-asserted between consecutive cycle operations.

Table 25: Attribute Memory Function

Function Mode	-REG	-CE2	-CE1	A9	A0	-OE	-WE	D15-D8	D7-D0
Standby	X	H	H	X	X	X	X	High Z	High Z
Read Byte Access CIS ROM (8 bits)	L	H	L	L	L	L	H	High Z	Even Byte
Write Byte Access CIS (8 bits) (Invalid)	L	H	L	L	L	H	L	Irrelevant	Even Byte
Read Byte Access Configuration (8 bits)	L	H	L	H	L	L	H	High Z	Even Byte
Write Byte Access Configuration (8 bits)	L	H	L	H	L	H	L	Irrelevant	Even Byte
Read Word Access CIS (16 bits)	L	L	L	L	X	L	H	Not Valid	Even Byte
Write Word Access CIS (16 bits) (Invalid)	L	L	L	L	X	H	L	Irrelevant	Even Byte
Read Word Access Configuration (16 bits)	L	L	L	H	X	L	H	Not Valid	Even Byte
Write Word Access Configuration (16 bits)	L	L	L	H	X	H	L	Irrelevant	Even Byte

3.4.2 Configuration Option Register (Address 200h in Attribute Memory)

The Configuration Option Register is used to configure the card's interface, address decoding and interrupt and to issue a soft reset to the CompactFlash Memory Card.

Operation	D7	D6	D5	D4	D3	D2	D1	D0
R/W	SRESET	LevIREQ	Conf5	Conf4	Conf3	Conf2	Conf1	Conf0

Bit	Name	Description
D7	SRESET	Setting this bit to one (1), waiting the minimum reset width time and returning to zero (0) places the card in the Reset state. Setting this bit to "1" is equivalent to assertion of the +RESET signal except that the SRESET bit is not cleared. Returning this bit to "0" leaves the card in the same unconfigured Reset state as following power-up and hardware reset. Using the PCMCIA Soft Reset is considered a hard reset by the ATA Commands, in contrast with Soft Reset in the Device Control Register.
D6	LevIREQ	This bit is set to "1" when Level Mode Interrupt is selected, and "0" when Pulse Mode is selected. Set to "0" by reset.
D5-D0	Conf5-Conf0	Configuration Index. Set to "0" by reset. This is used to select the card's mode of operation as shown below. Note: Conf5 and Conf4 are reserved and must be written as "0".

Table 26: Card Configurations

Conf5	Conf4	Conf3	Conf2	Conf1	Conf0	Disk Card Mode
0	0	0	0	0	0	Memory Mapped
0	0	0	0	0	1	I/O Mapped; any 16-byte system decoded boundary
0	0	0	0	1	0	I/O Mapped; 1F0-1F7/3F6-3F7
0	0	0	0	1	1	I/O Mapped; 170-177/376-377

3.4.3 Card Configuration and Status Register (Address 202h in Attribute Memory)

The Card Configuration and Status Register contain information about the condition of the card.

Operation	D7	D6	D5	D4	D3	D2	D1	D0
Read	Changed	SigChg	IOis8	0	0	PwrDwn	Int	0
Write	0	SigChg	IOis8	0	0	PwrDwn	0	0

Bit	Name	Description
D7	Changed	Indicates that one or both of the Pin Replacement Register CRdy, or CWProt bits are set to "1". When the Changed bit is set, -STSCHG Pin 46 is held low if the SigChg bit is a "1" and the card is configured for the I/O interface.
D6	SigChg	The host sets and resets this bit to enable and disable a state-change "signal" from the Status Register, the Changed bit control pin 46 the Changed Status signal. If no state change signal is desired, this bit should be set to zero "0" and pin 46 (-STSCHG) signal will be held high while the card is configured for I/O
D5	IOis8	The host sets this bit to one "1" if the card is to be configured in an 8-bit I/O mode. The card is always configured for both 8- and 16-bit I/O, so this bit is ignored.
D2	PwrDwn	This bit indicates whether the host requests the card to be in the power saving or active mode. When the bit is "1" the card enters a power down mode. When "0", the host requests that the card enter the active mode. The PCMCIA Rdy/-Bsy value becomes BUSY when this bit is changed. Rdy/-Bsy will not become Ready until the power state requested has been entered. The card automatically powers down when it is idle and powers back up when it receives a command
D1	Int	This bit represents the internal state of the interrupt request. This value is available whether or not I/O interface has been configured. This signal remains true until the condition that caused the interrupt request has been serviced. If interrupts are disabled by the -IEN bit in the Device Control Register, this bit is a "0".

3.4.4 Pin Replacement Register (Address 204h in Attribute Memory)

The Pin Replacement Register information is described below. Table 27: Pin Replacement Changed Bit/Mask Bit Values contains pin replacement changed bit/mask values.

Operation	D7	D6	D5	D4	D3	D2	D1	D0
Read	0	0	CRdy/-Bsy	CWProt	1	1	RRdy/-Bsy	RWProt
Write	0	0	CRdy/-Bsy	CWProt	0	0	MRdy/-Bsy	MWProt

Bit	Name	Description
D5	CRdy/-Bsy	This bit is set to "1" when the bit RRdy/-Bsy changes state. This bit can also be written by the host.
D4	CWProt	This bit is set to "1" when the RWprot changes state. This bit may also be written by the host.
D1	RRdy/-Bsy	This bit is used to determine the internal state of the Rdy/-Bsy signal. This bit may be used to determine the state of the Ready/-Busy as this pin has been reallocated for use as Interrupt Request on an I/O card. When written, this bit acts as a mask for writing the corresponding bit CRdy/-Bsy.
	MRdy/-Bsy	This bit acts as a mask for writing the corresponding bit CRdy/-Bsy.
D0	RWProt	This bit is always "0" because the card does not have a write-protect switch. When written, this bit acts as a mask for writing the corresponding bit CWProt.
	MWProt	This bit when written acts as a mask for writing the corresponding bit CWProt.

Table 27: Pin Replacement Changed Bit/Mask Bit Values

Initial Value of (C) Status	Written by Host		Final "C" Bit	Comments
	"C" Bit	"M" Bit		
0	X	0	0	Unchanged
1	X	0	1	Unchanged
X	0	1	0	Cleared by host
X	1	1	1	Set by host

3.4.5 Socket and Copy Register (Address 206h in Attribute Memory)

This register contains additional configuration information. This register is always written by the system before writing the card's Configuration Index Register.

Operation	D7	D6	D5	D4	D3	D2	D1	D0
Read	Reserved	0	0	Drive#	0	0	0	0
Write	0	0	0	Drive# (0)	X	X	X	X

Bit	Name	Description
D7	Reserved	This bit is reserved for future standardization. This bit must be set to "0" by the software when the register is written.
D4	Drive#	This bit indicates the drive number of the card if twin card configuration is supported.
D3-D0 (write)	X	The socket number is ignored by the card.

3.5 I/O Transfer Function

The following sections provide valuable information for the I/O Transfer function.

3.5.1 Common Memory Function

The Common Memory transfer to or from SanDisk CompactFlash memory cards can be either 8 or 16 bits. The card permits both 8- and 16-bit access to all its Common Memory addresses.

Table 28: Common Memory Function

Function Code	-REG	-CE2	-CE1	A0	-OE	-WE	D15-D8	D7-D0
Standby	X	H	H	X	X	X	High Z	High Z
Byte Read Access	H	H	L	L	L	H	High Z	Even Byte
(8 bits)	H	H	L	H	L	H	High Z	Odd Byte
Byte Write Access	H	H	L	L	H	L	Irrelevant	Even Byte
(8 bits)	H	H	L	H	H	L	Irrelevant	Odd Byte
Word Read Access (16 bits)	H	L	L	X	L	H	Odd Byte	Even Byte
Word Write Access (16 bits)	H	L	L	X	H	L	Odd Byte	Even Byte
Odd Byte Read Only (8 bits)	H	L	H	X	L	H	Odd Byte	High Z
Odd Byte Write Only (8 bits)	H	L	H	X	H	L	Odd Byte	Irrelevant

3.6 True IDE Mode I/O Transfer Function

This section contains valuable information on the True IDE Mode I/O Transfer function.

3.6.1 True IDE Mode I/O Function

SanDisk CompactFlash Memory cards can be configured in a True IDE Mode of operation. Cards are configured in this mode only when the -OE input signal is grounded by the host when power is applied to the cards. In this True IDE Mode, the PCMCIA protocol and configuration are disabled and only I/O operations to the Task File and Data Register are allowed. In this mode, no Memory or Attribute registers are accessible to the host. CompactFlash cards

permit 8-bit data accesses if the user issues a Set Feature Command to put the device in 8-bit mode.

Note: Removing and reinserting the card while the host computer's power is on will reconfigure the card to PC Card ATA mode from the original True IDE Mode. To configure the card in True IDE Mode, the 50-pin socket must be power cycled with the card inserted and -OE (output enable) grounded by the host.

Table 29: IDE Mode I/O Function defines the function of the operations for the True IDE Mode.

Table 29: IDE Mode I/O Function

Function Code	-CE2	-CE1	A0	-IORD	-IOWR	D15-D8	D7-D0
Invalid Mode	L	L	X	X	X	High Z	High Z
Standby Mode	H	H	X	X	X	High Z	High Z
Task File Write	H	L	1.7h	H	L	Irrelevant	Data In
Task File Read	H	L	1-7h	L	H	High Z	Data Out
Data Register Write	H	L	0	H	L	Odd Byte in	Even Byte In
Data Register Read	H	L	0	L	H	Odd Byte Out	Even Byte Out
Control Register Write	L	H	6h	H	L	Irrelevant	Control In
Alt Status Read	L	H	6h	L	H	High Z	Status Out

4. ATA Register Set and Protocol

SanDisk CompactFlash Memory cards can be configured as a high performance I/O device in the following ways:

- Standard PC-AT disk I/O address spaces 1F0h-1F7h, 3F6h-3F7h (primary); 170h-177h, 376h-377h (secondary) with IRQ 14 (or other available IRQ).
- Any system decoded 16-byte I/O block using any available IRQ.
- Memory space.

Communication to or from the card uses the Task File registers, which provide all the necessary registers for control and status information. The PCMCIA interface connects peripherals to the host using four register mapping methods. Table 30 describes these methods in detail.

Table 30: Standard I/O Configurations

Config Index	I/O or Memory	Address	Drive	Description
0	Memory	0-F, 400-7FF	0	Memory Mapped
1	I/O	XX0-XXF	0	I/O Mapped 16 Contiguous Registers
2	I/O	1F0-1F7, 3F6-3F7	0	Primary I/O Mapped Drive 0
2	I/O	1F0-1F7, 3F6-3F7	1	Primary I/O Mapped Drive 1
3	I/O	170-177, 376-377	0	Secondary I/O Mapped Drive 0
3	I/O	170-177, 376-377	1	Secondary I/O Mapped Drive 1

4.1 I/O Primary and Secondary Address Configurations

Table 31 contains configurations for primary and secondary I/O decoding.

Table 31: Primary and Secondary I/O Decoding

-REG	A9-A4	A3	A2	A1	A0	-IORD=0	-IOWR=0
0	1F(17)	0	0	0	0	Even RD Data a,b	Even WR Data a,b
0	1F(17)	0	0	0	1	Error Register a	Features a
0	1F(17)	0	0	1	0	Sector Count	Sector Count
0	1F(17)	0	0	1	1	Sector No.	Sector No.
0	1F(17)	0	1	0	0	Cylinder Low	Cylinder Low
0	1F(17)	0	1	0	1	Cylinder High	Cylinder High
0	1F(17)	0	1	1	0	Select Card/Head	Select Card/Head
0	1F(17)	0	1	1	1	Status	Command
0	3F(37)	0	1	1	0	Alt Status	Device Control
0	3F(37)	0	1	1	1	Drive Address	Reserved

- a. Register 0 is accessed with -CE1 low and -CE2 low (and A0 = Do not care) as a word register on the combined Odd Data Bus and Even Data Bus (D15-D0). This register may also be accessed by a pair of byte accesses to the offset 0 with -CE1 low and -CE2 high. Note that the address space of this word register overlaps the

address space of the Error and Feature byte-wide registers that lie at offset 1. When accessed twice as byte register with CE1 low, the first byte to be accessed is the even byte of the word and the second byte accessed is the odd byte of the equivalent word access.

- b. A byte access to register 0 with CE1 high and CE2 low accesses the error (read) or feature (write) register.

4.2 Contiguous I/O Mapped Addressing

When the system decodes a contiguous block of I/O registers to select a CompactFlash Memory Card, the registers are accessed in the block of I/O space decoded by the system as described in Table 32:

Table 32: Contiguous I/O Decoding

-REG	A3	A2	A1	A0	Offset	-IORD=0	-IOWR=0
0	0	0	0	0	0	Even RD Data a	Even WR Data a
0	0	0	0	1	1	Error Register b	Features b
0	0	0	1	0	2	Sector Count	Sector Count
0	0	0	1	1	3	Sector No.	Sector No.
0	0	1	0	0	4	Cylinder Low	Cylinder Low
0	0	1	0	1	5	Cylinder High	Cylinder High
0	0	1	1	0	6	Select Card/Head	Select Card/Head
0	0	1	1	1	7	Status	Command
0	1	0	0	0	8	Dup Even RD Data b	Dup Even WR Data b
0	1	0	0	1	9	Dup Odd RD Data b	Dup Odd WR Data b
0	1	1	0	1	D	Dup Error b	Dup Features b
0	1	1	1	0	E	Alt Status	Device Ctl
0	1	1	1	1	F	Drive Address	Reserved

- a. Register 0 is accessed with -CE1 low and -CE2 low (and A0 = Do not care) as a word register on the combined Odd Data Bus and Even Data Bus (D15-D0). This register may also be accessed by a pair of byte accesses to the offset 0 with -CE1 low and -CE2 high. Note that the address space of this word register overlaps the address space of the Error and Feature byte-wide registers that lie at offset 1. When accessed twice as byte register with CE1 low, the first byte to be accessed is the even byte of the word and the second byte accessed is the odd byte of the equivalent word access. A byte access to register 0 with CE1 high and CE2 low accesses the error (read) or feature (write) register.
- b. Registers at offset 8, 9 and D are non-overlapping duplicates of the registers at offset 0 and 1.

Register 8 is equivalent to register 0, while register 9 accesses the odd byte. Therefore, if the registers are byte accessed in the order 9 then 8 the data will be transferred odd byte then even byte. Repeated byte accesses to register 8 or 0 will access consecutive (even then odd) bytes from the data buffer. Repeated word accesses to register 8, 9 or 0 will access consecutive words from the data buffer. Repeated byte accesses to register 9 are not supported. However, repeated alternating byte accesses to registers 8 then 9 will access consecutive (even then odd) bytes from the data buffer. Byte accesses to register 9 access only the odd byte of the data.

4.3 Memory Mapped Addressing

When CompactFlash Memory Card registers are accessed via memory references, they appear in the common memory space window: 0-2K bytes as shown in Table 33.

Table 33: Memory Mapped Decoding

-REG	A10	A9A4	A3	A2	A1	A0	Offset	-OE=0	-WE=0
1	0	X	0	0	0	0	0	Even RD Data a	Even WR Data a
1	0	X	0	0	0	1	1	Error Register b	Features b
1	0	X	0	0	1	0	2	Sector Count	Sector Count
1	0	X	0	0	1	1	3	Sector No.	Sector No.
1	0	X	0	1	0	0	4	Cylinder Low	Cylinder Low
1	0	X	0	1	0	1	5	Cylinder High	Cylinder High
1	0	X	0	1	1	0	6	Select Card/Head	Select Card/Head
1	0	X	0	1	1	1	7	Status	Command
1	0	X	1	0	0	0	8	Dup Even RD Data b	Dup Even WR Data b
1	0	X	1	0	0	1	9	Dup Odd RD Data b	Dup Odd WR Data b
1	0	X	1	1	0	1	D	Dup Error b	Dup Features b
1	0	X	1	1	1	0	E	Alt Status	Device Ctl
1	0	X	1	1	1	1	F	Drive Address	Reserved
1	1	X	X	X	X	0	8	Even RD Data c	Even WR Data c
1	1	X	X	X	X	1	9	Odd RD Data c	Even RD Data c

- a. Register 0 is accessed with -CE1 low and -CE2 low (and A0 = Do not care) as a word register on the combined Odd Data Bus and Even Data Bus (D15-D0). This register may also be accessed by a pair of byte accesses to the offset 0 with -CE1 low and -CE2 high. Note that the address space of this word register overlaps the address space of the Error and Feature byte-wide registers that lie at offset 1. When accessed twice as byte register with CE1 low, the first byte to be accessed is the even byte of the word and the second byte accessed is the odd byte of the equivalent word access. A byte access to register 0 with CE1 high and CE2 low accesses the error (read) or feature (write) register.
- b. Registers at offset 8, 9 and D are non-overlapping duplicates of the registers at offset 0 and 1.

Register 8 is equivalent to register 0, while register 9 accesses the odd byte. Therefore, if the registers are byte accessed in the order 9 then 8 the data will be transferred odd byte then even byte. Repeated byte accesses to register 8 or 0 will access consecutive (even then odd) bytes from the data buffer. Repeated word accesses to register 8, 9 or 0 will access consecutive words from the data buffer. Repeated byte accesses to register 9 are not supported. However, repeated alternating byte accesses to registers 8 then 9 will access consecutive (even then odd) bytes from the data buffer. Byte accesses to register 9 access only the odd byte of the data.

- c. Accesses to even addresses between 400h and 7FFh access register 8. Accesses to odd addresses between 400h and 7FFh access register 9. This 1 KByte memory window to the data register is provided to enable hosts to

perform memory to memory block moves to the data register when the register lies in memory space. Some hosts, such as the X86 processors, must increment both the source and destination addresses when executing the memory to memory block move instruction. Some PCMCIA socket adapters also have auto-incrementing address logic embedded within them. This address window allows these hosts and adapters to function efficiently. Note that this entire window accesses the Data Register FIFO and does not allow random access to the data buffer within the card.

4.4 True IDE Mode Addressing

When a CompactFlash Memory Card is configured in True IDE Mode the I/O decoding is as listed in Table 34.

Table 34: True IDE Mode I/O Decoding

-CE2	-CE1	A2	A1	A0	-IORD=0	-IOWR=0
1	0	0	0	0	Even RD Data	Even WR Data
1	0	0	0	1	Error Register	Features
1	0	0	1	0	Sector Count	Sector Count
1	0	0	1	1	Sector No.	Sector No.
1	0	1	0	0	Cylinder Low	Cylinder Low
1	0	1	0	1	Cylinder High	Cylinder High
1	0	1	1	0	Select Card/Head	Select Card/Head
1	0	1	1	1	Status	Command
0	1	1	1	0	Alt Status	Device Control
0	1	1	1	1	Drive Address	Reserved

4.5 ATA Registers

In accordance with the PCMCIA specification, each of the following registers that is located at an odd offset address may be accessed at its normal address and also the corresponding even address (normal address -1) using data bus lines (D15-D8) when -CE1 is high and -CE2 is low, unless -IOIS16 is high (not asserted) and an I/O cycle is being performed.

4.5.1 Data Register (Address–1F0[170]; Offset 0, 8, 9)

The Data Register is a 16-bit register and is used to transfer data blocks between the CompactFlash Memory Card data buffer and the host. This register overlaps the Error Register. The information in the following table describes the combinations of data register access and is provided to assist in understanding the overlapped Data Register and Error/Feature Register rather than attempt to define general PCMCIA word and byte access modes and operations. Refer to the PCMCIA PC Card Standard Release 2.0 for definitions of the Card Accessing modes for I/O and memory cycles.

Note: Because of the overlapped registers, access to the 1F1, 171 or offset 1 is not defined for word (-CE2 = 0 and -CE1 = 0) operations. SanDisk products treat these accesses as accesses to the Word Data Register. The duplicated registers at offsets 8, 9 and Dh have no restrictions on the operations that can be performed by the socket.

Table 35: Data Register

Data Register	CE2	CE1	A0	Offset	Data Bus
Word Data Register	0	0	X	0,8,9	D15-D0
Even Data Register	1	0	0	0,8	D7-D0
Odd Data Register	1	0	1	9	D7-D0
Odd Data Register	0	1	X	8,9	D15-D0
Error/Feature Register	1	0	1	1,Dh	D7-D0
Error/Feature Register	0	1	X	1	D15-D0
Error/Feature Register	0	0	X	Dh	D15-D0

4.5.2 Error Register (Address–1F1[171]; Offset 1, 0Dh Read Only)

This register contains additional information about the source of an error when an error is indicated in bit 0 of the Status Register. The bits are defined as follows:

D7	D6	D5	D4	D3	D2	D1	D0
BBK	UNC	0	IDNF	0	ABRT	0	AMNF

This register is also accessed on data bits D15-D8 during a write operation to offset 0 with CE2 low and -CE1 high.

Bit	Name	Description
D7	BBK	Set when a bad block is detected.
D6	UNC	Set when an uncorrectable error is encountered.
D5	0	Bit set to 0.
D4	IDNF	The requested sector ID is in error or cannot be found.
D3	0	Bit set to 0.
D2	ABRT	Set if the command has been aborted because of a card status condition: (Not Ready, Write Fault, etc.) or when an invalid command has been issued.
D1	0	Bit set to 0.
D0	AMNF	Set in case of a general error.

4.5.3 Feature Register (Address–1F1[171]; Offset 1, 0Dh Write Only)

This register provides information about CompactFlash Memory Card features that the host can utilize. This register is also accessed on data bits D15-D8 during a write operation to Offset 0 with CE2 low and -CE1 high.

4.5.4 Sector Count Register (Address–1F2[172]; Offset 2)

This register contains the number of data sectors requested to be transferred on a read or write operation between the host and the card. If the value in this register is zero, a count of 256 sectors is specified. If the command was successful, this register will be "0" on completion of the command. If not successfully completed, the register will contain the number of sectors that need to be transferred in order to complete the request.

4.5.5 Sector Number (LBA 7-0) Register (Address–1F3[173]; Offset 3)

This register contains the starting sector number or bits 7-0 of the Logical Block Address (LBA) for any CompactFlash Memory Card data access for the subsequent command.

4.5.6 Cylinder Low (LBA 15-8) Register (Address–1F4[174]; Offset 4)

This register contains the low order 8 bits of the starting cylinder address or bits 15-8 of the Logical Block Address.

4.5.7 Cylinder High (LBA 23-16) Register (Address–1F5[175]; Offset 5)

This register contains the high order bits of the starting cylinder address or bits 23-16 of the Logical Block Address.

4.5.8 Drive/Head (LBA 27-24) Register (Address–1F6[176]; Offset 6)

The Drive/Head Register is used to select the drive and head. It is also used to select LBA addressing instead of cylinder/head/sector addressing. The bits are defined as follows:

D7	D6	D5	D4	D3	D2	D1	D0
1	LBA	1	DRV	HS3	HS2	HS1	HS0

Bit	Name	Description
D7	1	Bit set to 1.
D6	LBA	LBA is a flag to select either Cylinder/Head/Sector (CHS) or Logical Block Address Mode (LBA). When LBA=0, Cylinder/Head/Sector mode is selected. When LBA=1, Logical Block Address is selected. In Logical Block Mode, the Logical Block Address is interpreted as follows: LBA07-LBA00: Sector Number Register D7-D0. LBA15-LBA08: Cylinder Low Register D7-D0. LBA23-LBA16: Cylinder High Register D7-D0. LBA27-LBA24: Drive/Head Register bits HS3-HS0.
D5	1	Bit set to 1.

Bit	Name	Description
D4	DRV	DRV is the drive number. When DRV=0, drive (card) 0 is selected. When DRV=1, drive (card) 1 is selected. The CompactFlash Card is set to be Card 0 or 1 using the copy field of the PCMCIA Socket & Copy configuration register.
D3	HS3	When operating in the Cylinder, Head, Sector mode, this is bit 3 of the head number. It is Bit 27 in the Logical Block Address mode.
D2	HS2	When operating in the Cylinder, Head, Sector mode, this is bit 2 of the head number. It is Bit 26 in the Logical Block Address mode.
D1	HS1	When operating in the Cylinder, Head, Sector mode, this is bit 1 of the head number. It is Bit 25 in the Logical Block Address mode.
D0	HS0	When operating in the Cylinder, Head, Sector mode, this is bit 0 of the head number. It is Bit 24 in the Logical Block Address mode.

4.5.9 Status & Alternate Status Registers (Address—1F7[177]&3F6[376]; Offsets 7 & Eh)

These registers return the card status when read by the host. Reading the Status Register clears a pending interrupt, while reading the Auxiliary Status Register does not. The meaning of the status bits are described below:

D7	D6	D5	D4	D3	D2	D1	D0
BUSY	RDY	DWF	DSC	DRQ	CORR	0	ERR

Bit	Name	Description
D7	BUSY	Set when the CompactFlash Card has access to the command buffer and registers and the host is prevented from accessing the command register and buffer. No other bits in this register are valid when this bit is set to 1.
D6	RDY	RDY indicates whether the device is capable of performing card operations. This bit is cleared at power-up and remains cleared until card is ready to accept a command.
D5	DWF	If set, indicates a write fault has occurred.
D4	DSC	Set when the card is ready.
D3	DRQ	Set when the card requires information to be transferred either to or from the host through the Data Register.
D2	CORR	Set when a correctable data error has been encountered and the data has been corrected. This condition does not terminate a multi-sector read operation.
D1	0	Always set to 0.
D0	ERR	Set when the previous command ended in some type of error. The bits in the Error Register contain additional information describing the error.

4.5.10 Device Control Register (Address–3F6[376]; Offset Eh)

This register is used to control the CompactFlash Memory Card interrupt request and to issue an ATA soft reset to the card. The bits are defined as follows:

D7	D6	D5	D4	D3	D2	D1	D0
X	X	X	X	1	SW Rst	-IEEn	0

Bit	Name	Description
D7	X	Irrelevant.
D6	X	Irrelevant.
D5	X	Irrelevant.
D4	X	Irrelevant.
D3	1	Bit ignored by the card.
D2	SW Rst	Set to 1 in order to force the card to perform an AT Disk controller Soft Reset operation. This does not change the PCMCIA Card Configuration registers as a hardware reset does. The card remains in Reset until this bit is reset to "0".
D1	-IEEn	Interrupt Enable bit enables interrupts when the bit is 0. When the bit is 1, interrupts from the card are disabled. This bit also controls the Int bit in the Configuration and Status Register. This bit is set to 0 at power on and reset.
D0	ERR	Bit ignored by the card.

4.5.11 Card (Drive) Address Register (Address–3F7[377]; Offset Fh)

This register is provided for compatibility with the AT disk drive interface. This register should not be mapped into the host's I/O space because of potential conflicts on Bit 7. The bits are defined as follows:

D7	D6	D5	D4	D3	D2	D1	D0
X	-WTG	-HS3	-HS2	-HS1	-HS0	-nDS1	-nDS0

Bit	Name	Description
D7	X	<p>This bit is unknown. Implementation Note: Conflicts may occur on the host data bus when this bit is provided by a Floppy Disk Controller operating at the same addresses as the CompactFlash Memory Card. Following are some possible solutions to this problem for the PCMCIA implementation:</p> <ol style="list-style-type: none"> 1) Locate the CompactFlash Memory Card at a non-conflicting address, i.e., Secondary address (377) or in an independently decoded Address Space when a Floppy Disk Controller is located at primary addresses. 2) Do not install a Floppy and a CompactFlash Memory Card in the system at the same time 3) Implement a socket adapter that can be programmed to (conditionally) tri-state D7 of I/O address 3F7/377 when a CompactFlash Memory Card is installed and conversely to tri-state D6-D0 of I/O address 3F7/377 when a floppy controller is installed 4) Do not use the card's Drive Address Register. This can be accomplished by either programming the host adapter to enable only I/O addresses 1F0-1F7,

Bit	Name	Description
		3F6 (or 170-177, 176) to the card, if possible, or using an additional primary/secondary configuration in the card, if provided, that does not respond to accesses to I/O locations 3F7 and 377. With either of these implementations, the host software must not attempt to use information in the Drive Address Register.
D6	-WTG	This bit is 0 when a write operation is in progress, otherwise it is 1.
D5	-HS3	This bit is the negation of bit 3 in the Drive/Head Register.
D4	-HS2	This bit is the negation of bit 2 in the Drive/Head Register.
D3	-HS1	This bit is the negation of bit 1 in the Drive/Head Register.
D2	-HS0	This bit is the negation of bit 0 in the Drive/Head Register.
D1	-nDS1	This bit is 0 when drive 1 is active and selected.
D0	-nDS0	This bit is 0 when the drive 0 is active and selected.

5. ATA Command Description

This section defines the software requirements and the format of commands the host sends to CompactFlash Memory cards. Commands are issued to the card by loading the required registers in the command block with the supplied parameters, and then writing the command code to the Command Register. The manner in which a command is accepted varies. There are three classes (see Table 31: Primary and Secondary I/O Decoding) of command acceptance, all dependent upon the host only issuing commands when the card is not busy. (The BUSY bit in the status and alternate status registers is 0.)

Upon receipt of a Class 1 command, the card sets the BUSY bit within 400 nsec.

Upon receipt of a Class 2 command, the card sets the BUSY bit within 400 nsec, sets up the sector buffer for a write operation, sets DRQ within 700 µsec, and clears the BUSY bit within 400 nsec of setting DRQ.

Upon receipt of a Class 3 command, the card sets the BUSY bit within 400 nsec, sets up the sector buffer for a write operation, sets DRQ within 20 msec (assuming no re-assignments), and clears the BUSY bit within 400 nsec of setting DRQ.

5.1 ATA Command Set

Table36 summarizes the ATA command set with the paragraphs that follow describing the individual commands and the task file for each.

Table36: Primary and Secondary I/O Decoding

Class	Command	Code	FR	SC	SN	CY	DH	LBA
1	Check Power Mode	E5h or 98h	-	-	-	-	D	-
1	Execute Drive Diagnostic	90h	-	-	-	-	D	-
1	Erase Sector(s) a	C0h	-	Y	Y	Y	Y	Y
2	Format Track	50h	-	Y	-	Y	Y	Y
1	Identify Device	ECh	-	-	-	-	D	-
1	Idle	E3h or 97h	-	Y	-	-	D	-
1	Idle Immediate	E1h or 95h	-	-	-	-	D	-
1	Initialize Drive Parameters	91h	-	Y	-	-	Y	-
1	Read Buffer	E4h	-	-	-	-	D	-
1	Read DMA	C8 or C9	-	Y	Y	Y	Y	Y
1	Read Multiple	C4h	-	Y	Y	Y	Y	Y
1	Read Long Sector	22h or 23h	-	-	Y	Y	Y	Y
1	Read Sector(s)	20h or 21h	-	Y	Y	Y	Y	Y
1	Read Verify Sector(s)	40h or 41h	-	Y	Y	Y	Y	Y
1	Recalibrate	1Xh	-	-	-	-	D	-
1	Request Sense b	03h	-	-	-	-	D	-
1	Seek	7Xh	-	-	Y	Y	Y	Y
1	Set Features	EFh	Y	-	-	-	D	-
1	Set Multiple Mode	C6h	-	Y	-	-	D	-
1	Set Sleep Mode	E6h or 99h	-	-	-	-	D	-

Class	Command	Code	FR	SC	SN	CY	DH	LBA
1	Stand By	E2h or 96h	-	-	-	-	D	-
1	Stand By Immediate	E0h or 94h	-	-	-	-	D	-
1	Translate Sector b	87h	-	Y	Y	Y	Y	Y
1	Wear Levelb	F5h	-	-	-	-	Y	-
2	Write Buffer	E8h	-	-	-	-	D	-
2	Write DMA	CA or CB	-	Y	Y	Y	Y	Y
2	Write Long Sector	32h or 33h	-	-	Y	Y	Y	Y
3	Write Multiple	C5h	-	Y	Y	Y	Y	Y
3	Write Multiple w/o Erase a	CDh	-	Y	Y	Y	Y	Y
2	Write Sector(s)	30h or 31h	-	Y	Y	Y	Y	Y
2	Write Sector(s) w/o Erase a	38h	-	Y	Y	Y	Y	Y
2	Write Verify	3Ch	-	Y	Y	Y	Y	Y

- a. These commands are not standard PC Card ATA commands and these features are no longer supported with the introduction of 256 Mbit Flash Technology. If one of these commands is issued, the sectors will be erased but there will be no net gain in write performance when using the Write Without Erase command.
- b. These commands are not standard PC Card ATA commands but provide additional functionality.

Abbreviation	Key
FR	Features Register
SC	Sector Count Register
SN	Sector Number Register
CY	Cylinder Registers
DH	Card/Drive/Head Register
LBA	Logical Block Address Mode Supported
Y	The register contains a valid parameter for this command. For the Drive/Head Register, both the CompactFlash Card and head parameters are used
D	The register contains a valid parameter for this command. For the Drive/Head Register, only the CompactFlash Card parameter is valid and not the head parameter

5.1.1 Check Power Mode—98H, E5H

This command checks the power mode.

If the CompactFlash Card is in, about to enter, or recovering from sleep mode, it sets BSY, sets the Sector Count Register to 00h, clears BSY and generates an interrupt.

If the card is in Idle mode, it sets BSY, sets the Sector Count Register to FFh, clears BSY and generates an interrupt.

Table 37: Check Power Mode

Bit	7	6	5	4	3	2	1	0
Command (7)	E5H or 98H							
C/D/H (6)	X			Drive		X		
Cyl High (5)					X			
Cyl Low (4)					X			
Sec Num (3)					X			
Sec Cnt (2)					X			
Feature (1)					X			

5.1.2 Execute Drive Diagnostic–90H

This command performs the internal diagnostic tests implemented by the CompactFlash cards.

Table 38: Execute Drive Diagnostic

Bit	7	6	5	4	3	2	1	0
Command (7)	90H							
C/D/H (6)	X			Drive		X		
Cyl High (5)					X			
Cyl Low (4)					X			
Sec Num (3)					X			
Sec Cnt (2)					X			
Feature (1)					X			

The diagnostic codes shown in Table 39 are returned in the Error Register at the end of the command.

Table 39: Diagnostic Codes

Code	Error Type
01h	No error detected
02h	Formatter device error
03h	Sector buffer error
04h	ECC circuitry error
05h	Controlling microprocessor error
8Xh	Slave failed (True IDE Mode)

5.1.3 Erase Sector(s)–C0H

This command is no longer recommended. There is essentially no net gain in the use of the Erase Sectors and/or the Write Without Erase Commands. This command is supported to guarantee backward compatibility.

Table 40: Table: Erase Sector(s)

Bit	7	6	5	4	3	2	1	0
Command (7)	C0H							
C/D/H (6)	1	LBA	1	Drive	Head (LBA 27-24)			
Cyl High (5)					Cylinder High (LBA 23-16)			
Cyl Low (4)					Cylinder Low (LBA 15-8)			
Sec Num (3)					Sector Number (LBA 7-0)			
Sec Cnt (2)					Sector Number (LBA 7-0)			
Feature (1)					X			

5.1.4 Format Track–50H

This command writes the desired head and cylinder of the selected drive with an FFh pattern. To remain host backward compatible, the card expects a sector buffer of data from the host to follow the command with the same protocol as the Write Sector(s) command, although the card does not use the information in the buffer. If LBA=1 then the number of sectors to format is taken from the Sec Cnt register (0=256).

Note: The Format Track command in Table 41 is no longer recommended. The command is supported to guarantee backward compatibility.

Table 41: Format Track

Bit	7	6	5	4	3	2	1	0
Command (7)	50H							
C/D/H (6)	1	LBA	1	Drive	Head (LBA 27-24)			
Cyl High (5)	Cylinder High (LBA 23-16)							
Cyl Low (4)	Cylinder Low (LBA 15-8)							
Sec Num (3)	X (LBA 7-0)							
Sec Cnt (2)	Count (LBA mode only)							
Feature (1)	X							

5.1.5 Identify Device–ECH

The Identify Drive command enables the host to receive parameter information from a CompactFlash Memory Card. This command has the same protocol as the Read Sector(s) command. The parameter words in the buffer have the arrangement and meanings defined in Table 5-8. All reserved bits or words are "0".

Table 42: Identify Device

Bit	7	6	5	4	3	2	1	0
Command (7)	ECH							
C/D/H (6)	X	X	X	Drive	X			
Cyl High (5)	X							
Cyl Low (4)	X							
Sec Num (3)	X							
Sec Cnt (2)	X							
Feature (1)	X							

Table 43 defines each field in the Identify Device Information.

Table 43: Identify Device Information

Word Address	Default Value	Total Bytes	Data Field Type Information
0	848Ah	2	General configuration bit-significant information
1	XXXXh	2	Default number of cylinders
2	0000h	2	Reserved
3	XXXXh	2	Default number of heads
4	0000h	2	Number of unformatted bytes per track
5	0000h	2	Number of unformatted bytes per sector
6	XXXXh	2	Default number of sectors per track

Word Address	Default Value	Total Bytes	Data Field Type Information
7-8	XXXXh	4	Number of sectors per card (Word 7 = MSW, Word 8 = LSW)
9	0000h	2	Reserved
10-19	aaaa	20	Serial number in ASCII (right justified)
20	0000h	2	Buffer type (dual ported)
21	0000h	2	Buffer size in 512 byte increments
22	0004h	2	Number of ECC bytes passed on Read/Write Long Commands
23-26	aaa	8	Firmware revision in ASCII (Rev M.ms) set by code Big Endian Byte Order in Word
27-46	aaaa	40	Model number in ASCII (left justified) Big Endian Byte Order in Word
47	000Xh	2	Maximum No. of Sectors on Read/Write Multiple command
48	0000h	2	Double-word not supported
49	0X00ha	2	Capabilities: DMA Supported (bit 8), LBA supported (bit 9)
50	0000h	2	Reserved
51	0200h	2	PIO data transfer cycle timing mode
52	0000h	2	Single word DMA data transfer cycle timing mode (not supported)
53	0003h	2	Field validity
54	XXXXh	2	Current number of cylinders
55	XXXXh	2	Current number of heads
56	XXXXh	2	Current sectors per track
57-58	XXXXh	4	Current capacity in sectors (LBAs) (Word 57 = LSW, Word 58 = MSW)
59	010Xh	2	Multiple sector setting is valid
60-61	XXXXh	4	Total number of sectors addressable in LBA Mode
62	0000h	2	Single word DMA transfer (not supported)
63	0X07h	2	0-7: Multiword DMA modes supported 15-8: Multiword DMA mode active
64	0003h	2	Advanced PIO modes supported
65	0078h (IDE Mode only)	2	Minimum multiword DMA transfer cycle time per word in ns
66	0078h (IDE Mode only)	2	Recommended multiword DMA transfer cycle time per word in ns
67	0078h	2	Minimum PIO transfer without flow control
68	0078h	2	Minimum PIO transfer with IORDY flow control
69-79	0000h	20	Reserved
80	00XXh	2	Major ATA version
81	0000h	2	Minor ATA version
82	00X0h	2	Features/command sets supported
83	4004h	2	Features/command sets supported
84	4000h	2	Features/command sets supported
85	0000h	2	Features/command sets enabled
86	0004h	2	Features/command sets enabled
87	4000h	2	Features/command sets enabled

Word Address	Default Value	Total Bytes	Data Field Type Information
88	0000h	2	Ultra DMA Mode supported and selected
89	XXXXh	2	Time required for security erase-unit completion
90	0000h	2	Time required for enhanced security erase-unit completion
91	XXXXh	2	Current advanced power management value
92-127	0000h	72	Reserved
128-159	0000h	64	Reserved vendor-unique bytes
160	0000h	2	Power requirement description
161	0000h	2	Reserved for assignment by the CFA
162	0000h	2	Key management schemes supported
163	00XXh	2	CF Advanced True IDE Timing Mode Capability and Setting
164	001Bh	2	CF Advanced PCMCIA I/O and Memory Timing Mode Capability
165-175	0000h	22	Reserved for assignment by the CFA
176-255	0000h	140	Reserved

SanDisk PCMCIA supports Multiword DMA. For all unsupported cases, 0100H is reported in word 49, and 0000H is reported in words 52, 63, and 65. CompactFlash products will support multi-word.

Word 0: General Configuration. This field informs the host that this is a non-magnetic, hard sectored, removable storage device with a transfer rate greater than 10 Mb/sec and is not MFM encoded. CompactFlash products report 848AH in compliance with the CFA specification.

Word 1: Default Number of Cylinders. This field contains the number of translated cylinders in the default translation mode. This value will be the same as the number of cylinders.

Word 3: Default Number of Heads. This field contains the number of translated heads in the default translation mode.

Word 4: Number of Unformatted Bytes per Track. This field contains the number of unformatted bytes per translated track in the default translation mode.

Word 5: Number of Unformatted Bytes per Sector. This field contains the number of unformatted bytes per sector in the default translation mode.

Word 6: Default Number of Sectors per Track. This field contains the number of sectors per track in the default translation mode.

Words 7-8: Number of Sectors per Card. This field contains the number of sectors per CompactFlash Memory Card. This double word value is also the first invalid address in LBA translation mode.

Words 10-19: Memory Card Serial Number. The contents of this field are right justified and padded with spaces (20h).

Word 20: Buffer Type. This field defines the buffer capability with the 0002h, meaning a dual ported multi-sector buffer capable of simultaneous data transfers to or from the host and the CompactFlash Memory Card.

Word 21: Buffer Size. This field defines the buffer capacity of 2 sectors or 1 kilobyte of SRAM.

Word 22: ECC Count. This field defines the number of ECC bytes used on each sector in the Read and Write Long commands.

Words 23-26: Firmware Revision. This field contains the relevant firmware version for the product.

Words 27-46: Model Number. This field contains the product model number and is left justified and padded with spaces (20h).

Word 47: Read/Write Multiple Sector Count. This field contains the maximum number of sectors that can be read or written per interrupt using the Read Multiple or Write Multiple commands.

Word 48: Double Word Support. This field indicates this product will not support double word transfers.

Word 49: Capabilities. This field indicates if this product supports DMA Data transfers and LBA mode. All SanDisk products support LBA mode.

Word 51: PIO Data Transfer Cycle Timing Mode. To determine the proper device timing category, compare the Cycle Time specified in Table 21 with the contents of this field in Table 20.

t_0 is the minimum total cycle time, t_2 is the minimum command active time, and t_{2i} is the minimum command recovery time or command inactive time. The actual cycle time equals the sum of the actual command active time and the actual command inactive time. The three timing requirements of t_0 , t_2 , and t_{2i} shall be met. The minimum total cycle time requirements are greater than the sum of t_2 and t_{2i} . This means a host implementation may lengthen either or both t_2 or t_{2i} to ensure that t_0 is equal to or greater than the value reported in the devices IDENTIFY DEVICE data. A device implementation shall support any legal host implementation.

The IORD-data tri-state parameter specifies the time from the negation edge of /IORD to the time that the data bus is no longer driven by the device (tri-state).

Note: For backward compatibility with BIOS written before the definition of Word 64 for advanced modes, a device reports the highest original PIO mode it can support in Word 51 (i.e., PIO mode 0, 1 or 2).

Word 52: Single Word DMA Data Transfer Cycle Timing Mode. This field states that this product does not support any Single Word DMA data transfer mode.

Word 53: Translation Parameters Valid. Bit 0 of this field is set, indicating that words 54 to 58 are valid and reflect the current number of cylinders, heads and sectors. Bit 1 is also set, indicating values in words 64 through 70 are valid.

Words 54-56: Current Number of Cylinders, Heads, Sectors/Track. These fields contain the current number of user addressable cylinders, heads, and sectors/track in the current translation mode.

Words 57-58: Current Capacity. This field contains the product of the current cylinders x heads x sectors.

Word 59: Multiple Sector Setting. This field contains a validity flag in the odd byte and the current number of sectors that can be transferred per

interrupt for R/W Multiple in the even byte. The odd byte is always 01H, which indicates that the even byte is always valid.

The even byte value depends on the value set by the Set Multiple command. The even byte of this word by default contains a 00H, which indicates that R/W Multiple commands are not valid. The only other value returned by the CompactFlash Memory Card in the even byte is a 01H value, which indicates that 1 sector per interrupt, can be transferred in R/W Multiple mode.

Words 60-61: Total Sectors Addressable in LBA Mode. This field contains the number of sectors addressable for the CompactFlash Card in LBA mode only.

Word 64: Advanced PIO Transfer Modes Supported. Bits 0 and 1 of this field are set to indicate support for PIO transfer modes 3 and 4, respectively.

Word 65: Minimum Multiword DMA Transfer Cycle Time per Word. Word 65 of the parameter information of the IDENTIFY DEVICE command is defined as the Minimum Multiword DMA Transfer Cycle Time per Word. This field defines the minimum cycle time, in nanoseconds, that the device can support when performing Multiword DMA transfers on a per word basis.

Word 66: Recommended Multiword DMA Cycle Time. Word 66 of the parameter information of the IDENTIFY DEVICE command is defined as the Recommended Multiword DMA Transfer Cycle Time. This field defines the minimum cycle time, in nanoseconds, per word during a single sector host transfer while performing a multiple sector READ DMA or WRITE DMA commands over all locations on the media under minimal conditions. If a host runs at a faster cycle rate by operating at a cycle time of less than this value, the device may negate DMARQ for flow control. The rate at which DMARQ is negated could result in reduced throughput, despite the faster cycled rate. Transfer at this rate does not ensure that flow control will not be used, but implies that higher performance may result.

Word 67: Minimum PIO Transfer Cycle Time Without Flow Control. This field indicates the minimum cycle time, in nanoseconds, that, if used by the host, the card guarantees data integrity during the cycle without utilization of flow control.

Word 68: Minimum PIO Transfer Cycle Time With Flow Control. This field indicates the minimum cycle time, in nanoseconds, that the card supports while performing data transfers using flow control.

Words 82-84: Features/Command Sets Supported. Words 82, 83, and 84 indicate the features and command sets supported. The value 0000h or FFFFh was placed in each of these words by CompactFlash cards prior to ATA-3 and will be interpreted by the host as meaning that features/command sets supported are not indicated. Bits 1 through 13 of Word 83, and bits 0 through 13 of Word 84 are reserved. Bit 14 of Word 83 and Word 84 will be set to "1," and bit 15 of Word 83 and Word 84 will be cleared to zero which indicates that the features and command sets supported words are valid. Host implementers should not depend upon the values in these words.

Table 44: Word 82 Description

Bit	Setting	Indication
0	0	SMART feature set not supported
1	1	Security Mode feature set supported
2	0	Removable Media feature set not supported
3	1	Power Management feature set supported
4	0	Packet Command feature set not supported
5	1	Write cache supported
6	1	Look-ahead supported
7	0	Release Interrupt not supported
8	0	Service Interrupt not supported
9	0	Device Reset command not supported
10	0	Host Protected Area feature set not supported
11		Obsolete
12	1	Write Buffer command supported by CF Card
13	1	Read Buffer command supported by CF Card
14	1	NOP command supported by CF Card
15		Obsolete

Table 45: Word 83 Description

Bit	Setting	Indication
0	0	Download Microcode command not supported by CF Card
1	0	Read DMA Queued and Write DMA Queued commands not supported by CF Card
2	1	CFA feature set supported by CF Card
3	1	Advanced Power Management feature set supported by CF Card
4	0	Removable Media Status feature set not supported by CF Card

Words 85-87: Features/Command Sets Enabled. Words 85, 86, and 87 indicate features/command sets enabled. The value 0000h or FFFFh was placed in each of these words by CompactFlash cards prior to ATA-4 and will be interpreted by the host as meaning that features/command sets enabled are not indicated. Bits 1 through 15 of word 86 are reserved.

Bits 0-13 of word 87 are reserved. Bit 14 of word 87 will be set to one and bit 15 of word 87 will be cleared to zero to provide indication that the features/command sets enabled words are valid. Host implementers should not depend upon the values in these words.

Table 46: Word 85 Description

Bit	Setting	Indication
0	0	SMART feature set not enabled
1	1	Security Mode feature set enabled via the Security Set Password command
2	0	Removable Media feature set not supported
3	1	Power Management feature set supported
4	0	Packet Command feature set not enabled

Bit	Setting	Indication
5	1	Write cache enabled
6	1	Look-ahead enabled
7	0	Release Interrupt not enabled
8	0	Service Interrupt not enabled
9	0	Device Reset command not supported
10	0	Host Protected Area feature set not supported
11		Obsolete
12	1	Write Buffer command supported by CF Card
13	1	Read Buffer command supported by CF Card
14	1	NOP command supported by CF Card
15		Obsolete

Table 47: Word 86 Description

Bit	Setting	Indication
0	0	Download Microcode command not supported by CF Card
1	0	Read DMA Queued and Write DMA Queued commands not supported by CF Card
2	1	CFA feature set supported by CF Card
3	1	Advanced Power Management feature set by Set Features command
4	0	Removable Media Status feature set not supported by CF Card

Word 163: CF Advanced True IDE Timing Mode Capabilities and Settings. This word describes the capabilities and current settings for CFA defined advanced timing modes using the True IDE interface.

Four separate fields are defined that describe support and selection of Advanced PIO timing modes and Advanced Multiword DMA timing modes. The older modes are reported in Word 63: Multiword DMA Transfer and Word 64: Advanced PIO Transfer Modes Supported.

Bits 2-0: Advanced True IDE PIO Mode Support

Indicates the maximum True IDE PIO mode supported by the card.

Value	Maximum PIO Mode Timing Supported
0	Specified in Word 64
1	PIO Mode 5
2	PIO Mode 6
3-7	Reserved

Bits 5-3: Advanced True IDE Multiword DMA Mode Support

Indicates the maximum True IDE Multiword DMA mode supported by the card.

Value	Maximum Multiword DMA Mode Timing Supported
0	Specified in Word 63
1	Multiword DMA Mode 3
2	Multiword DMA Mode 4
3-7	Reserved

Bits 8-6: Advanced True IDE PIO Mode Selected

Indicates the current True IDE PIO mode selected on the card.

Value	Current PIO Timing Mode Selected
0	Specified in Word 64
1	PIO Mode 5
2	PIO Mode 6
3-7	Reserved

Bits 11-9: Advanced True IDE Multiword DMA Mode Selected

Indicates the current True IDE Multiword DMA Mode Selected on the card.

Value	Current Multiword DMA Timing Mode Selected
0	Specified in Word 63
1	Multiword DMA Mode 3
2	Multiword DMA Mode 4
3-7	Reserved

Bits 15-12: Reserved

Word 164: CF Advanced PCMCIA I/O and Memory Timing Mode Capabilities and Settings. This word describes the capabilities and current settings for CFA defined advanced timing modes using the Memory and PCMCIA I/O interface.

Bits 2-0: Maximum Advanced PCMCIA I/O Mode Support

Indicates the maximum I/O timing mode supported by the card.

Value	Maximum PCMCIA I/O Timing Mode Supported
0	255 ns Cycle PCMCIA I/O Mode
1	120 ns Cycle PCMCIA I/O Mode
2	100 ns Cycle PCMCIA I/O Mode
3	80 ns Cycle PCMCIA I/O Mode
4-7	Reserved

Bits 5-3: Maximum Memory Timing Mode Supported

Indicates the Maximum Memory timing mode supported by the card.

Value	Maximum Memory Timing Mode Supported
0	250 ns Cycle Memory Mode
1	120 ns Cycle Memory Mode
2	100 ns Cycle Memory Mode
3	80 ns Cycle Memory Mode
4-7	Reserved

Bits 15-6: Reserved

5.1.6 Idle–97H, E3H

This command causes the card to set BSY, enter the Idle (Read) mode, clear BSY and generate an interrupt. If the sector count is not zero, it is interpreted as a timer count with each count being 5 milliseconds and the automatic power down mode is enabled. If the sector count is zero, the automatic power down mode is disabled.

Note: This time base (5 msec) is different from the ATA specification.

Table 48: Idle

Bit	7	6	5	4	3	2	1	0
Command (7)	E3H or 97H							
C/D/H (6)		X		Drive			X	
Cyl High (5)					X			
Cyl Low (4)					X			
Sec Num (3)					X			
Sec Cnt (2)						Timer Count (5 ms increments)		
Feature (1)					X			

5.1.7 Idle Immediate–95H, E1H

This command causes the card to set BSY, enter the Idle (Read) mode, clear BSY and generate an interrupt.

Table 49: Idle Immediate

Bit	7	6	5	4	3	2	1	0
Command (7)	E1H or 95H							
C/D/H (6)		X		Drive			X	
Cyl High (5)					X			
Cyl Low (4)					X			
Sec Num (3)					X			
Sec Cnt (2)					X			
Feature (1)					X			

5.1.8 Initialize Drive Parameters–91H

This command enables the host to set the number of sectors per track and the number of heads per cylinder. Only This command uses only the Sector Count and the Card/Drive/Head registers.

Note: SanDisk does not recommend using this command in any system because DOS determines the offset to the Boot Record based on the number of heads and sectors per track. If a CompactFlash Memory Card is "Formatted" with one head and sector per track value, the same card will not operate correctly with DOS configured with another head and sector per track value.

Table 50: Initialize Drive Parameters

Bit	7	6	5	4	3	2	1	0
Command (7)	91H							
C/D/H (6)	X	0	X	Drive	Max. Head (no. of heads - 1)			
Cyl High (5)	X							
Cyl Low (4)	X							
Sec Num (3)	X							
Sec Cnt (2)	Number of Sectors							
Feature (1)	X							

5.1.9 Read Buffer–E4H

The Read Buffer command enables the host to read the current contents of the card's sector buffer. This command has the same protocol as the Read Sector(s) command.

Table 51: Read Buffer

Bit	7	6	5	4	3	2	1	0
Command (7)	E4H							
C/D/H (6)	X			Drive	X			
Cyl High (5)	X							
Cyl Low (4)	X							
Sec Num (3)	X							
Sec Cnt (2)	X							
Feature (1)	X							

5.1.10 Read DMA Command–C8H, C9H

The Read DMA command in Table 5-17 executes in a similar manner to the READ SECTOR(S) command except for the following:

The host initializes the DMA channel prior to issuing the command.

Data transfers are qualified by DMARQ and are performed by the DMA channel.

The device issues only one interrupt per command to indicate that data transfer has terminated and status is available.

During the DMA transfer phase of a Read DMA command, the device provides status of the BSY bit or the DRQ bit until the command is completed.

Table 52: Read DMA Command

Bit	7	6	5	4	3	2	1	0
Command (7)	ECH							
C/D/H (6)	X	X	X	Drive	X			
Cyl High (5)	X							
Cyl Low (4)	X							
Sec Num (3)	X							
Sec Cnt (2)	X							
Feature (1)	X							

5.1.11 Read Multiple–C4H

The Read Multiple command performs similarly to the Read Sectors command. Interrupts are not generated on every sector, but on the transfer of a block that contains the number of sectors defined by a Set Multiple command.

Table 53: Read DMA Command

Bit	7	6	5	4	3	2	1	0
Command (7)	C4H							
C/D/H (6)	1	LBA	1	Drive	Head (LBA 27-24)			
Cyl High (5)	Cylinder High (LBA 23-16)							
Cyl Low (4)	Cylinder Low (LBA 15-8)							
Sec Num (3)	Sector Number (LBA 7-0)							
Sec Cnt (2)	Sector Count							
Feature (1)	X							

Command execution is identical to the Read Sectors operation except that the number of sectors defined by a Set Multiple command is transferred without intervening interrupts. DRQ qualification of the transfer is required only at the start of the data block, not on each sector.

The block count of sectors to be transferred without intervening interrupts is programmed by the Set Multiple Mode command, which must be executed prior to the Read Multiple command. When the Read Multiple command is issued, the Sector Count Register contains the number of sectors (not the number of blocks or the block count) requested. If the number of requested sectors is not evenly divisible by the block count, as many full blocks as possible are transferred, followed by a final, partial block transfer. The partial block transfer is for n sectors, where: $n = (\text{sector count}) - \text{module}(\text{block count})$.

If the Read Multiple command is attempted before the Set Multiple Mode command has been executed, or when Read Multiple commands are disabled, the Read Multiple operation is rejected with an Aborted Command error. Disk errors encountered during Read Multiple commands are posted at the beginning of the block or partial block transfer, but DRQ is still set and the data transfer will take place as it normally would, including transfer of corrupted data, if any.

Interrupts are generated when DRQ is set at the beginning of each block or partial block. The error reporting is the same as that on a Read Sector(s) Command. This command reads from 1 to 256 sectors as specified in the Sector Count register. A sector count of 0 requests 256 sectors. The transfer begins at the sector specified in the Sector Number Register.

On command completion, the Command Block registers contain the cylinder, head and sector number of the last sector read.

If an error occurs, the read terminates at the sector where the error occurred. The Command Block registers contain the cylinder, head and sector number of the sector where the error occurred. The flawed data is pending in the sector buffer.

Subsequent blocks or partial blocks are transferred only if the error was a correctable data error. All other errors cause the command to stop after transfer of the block that contained the error.

5.1.12 Read Long Sector–22H, 23H

The Read Long command performs similarly to the Read Sector(s) command except that it returns 516 bytes of data instead of 512 bytes. During a Read Long command, the card does not check the ECC bytes to determine if there has been a data error. Only single sector read long operations are supported. The transfer consists of 512 bytes of data transferred in word mode followed by 4 bytes of random data transferred in byte mode. Random data is returned instead of ECC bytes because of the nature of the ECC system used. This command has the same protocol as the Read Sector(s) command.

Table 54: Read Long Sector

Bit	7	6	5	4	3	2	1	0
Command (7)	22H or 23H							
C/D/H (6)	1	LBA	1	Drive	Head (LBA 27-24)			
Cyl High (5)	Cylinder High (LBA 23-16)							
Cyl Low (4)	Cylinder Low (LBA 15-8)							
Sec Num (3)	Sector Number (LBA 7-0)							
Sec Cnt (2)	X							
Feature (1)	X							

5.1.13 Read Sector(s)–20H, 21H

This command reads from 1 to 256 sectors as specified in the Sector Count Register. A sector count of 0 requests 256 sectors. The transfer begins at the sector specified in the Sector Number Register. When this command is issued, and after each sector of data (except the last one) has been read by the host, the CompactFlash card sets BSY, puts the sector of data in the buffer, sets DRQ, clears BSY, and generates an interrupt. The host then reads the 512 bytes of data from the buffer.

On command completion, the Command Block registers contain the cylinder, head and sector number of the last sector read. If an error occurs, the read terminates at the sector where the error occurred. The Command Block registers contain the cylinder, head, and sector number of the sector where the error occurred. The flawed data is pending in the sector buffer.

Table 55: Read Sector(s)

Bit	7	6	5	4	3	2	1	0
Command (7)	20H or 21H							
C/D/H (6)	1	LBA	1	Drive	Head (LBA 27-24)			
Cyl High (5)	Cylinder High (LBA 23-16)							
Cyl Low (4)	Cylinder Low (LBA 15-8)							
Sec Num (3)	Sector Number (LBA 7-0)							
Sec Cnt (2)	Sector Count							
Feature (1)	X							

5.1.14 Read Verify Sector(s)–40H, 41H

This command is identical to the Read Sectors command, except that DRQ is never set and no data is transferred to the host. When the command is accepted, the card sets BSY.

When the requested sectors have been verified, the card clears BSY and generates an interrupt. Upon command completion, the Command Block

registers contain the cylinder, head, and sector number of the last sector verified.

If an error occurs, the Verify command terminates at the sector where the error occurs. The Command Block registers contain the cylinder, head and sector number of the sector where the error occurred. The Sector Count Register contains the number of sectors not yet verified.

Table 56: Read Verify Sector(s)

Bit	7	6	5	4	3	2	1	0
Command (7)	40H or 41H							
C/D/H (6)	1	LBA	1	Drive	Head (LBA 27-24)			
Cyl High (5)	Cylinder High (LBA 23-16)							
Cyl Low (4)	Cylinder Low (LBA 15-8)							
Sec Num (3)	Sector Number (LBA 7-0)							
Sec Cnt (2)	Sector Count							
Feature (1)	X							

5.1.15 Recalibrate–1XH

This command is effectively a NOP command to the CompactFlash Memory Card and is provided for compatibility purposes. After this command is executed the Cyl High and Cyl Low as well as the Head number will be 0 and Sec Num will be 1 if LBA=0 and 0 if LBA=1 (i.e., the first block in LBA is 0 while CHS mode the sector number starts at 1).

Table 57: Recalibrate

Bit	7	6	5	4	3	2	1	0
Command (7)	1XH							
C/D/H (6)	1	LBA	1	Drive	X			
Cyl High (5)	X							
Cyl Low (4)	X							
Sec Num (3)	X							
Sec Cnt (2)	X							
Feature (1)	X							

5.1.16 Request Sense–03H

This command requests an extended error code after a command ends with an error.

Table 58: Request Sense

Bit	7	6	5	4	3	2	1	0
Command (7)	03H							
C/D/H (6)	1	X	1	Drive	X			
Cyl High (5)	X							
Cyl Low (4)	X							
Sec Num (3)	X							
Sec Cnt (2)	X							
Feature (1)	X							

Table 59 defines the valid extended error codes for the CompactFlash Memory Card Series product. The extended error code is returned to the host in the Error Register. This command must be the subsequent command issued to the card following the command that returned an error.

Table 59: Extended Error Codes

Extended Error Code	Description
00h	No error detected
01h	Self test OK (no error)
09h	Miscellaneous error
20h	Invalid command
21h	Invalid address (requested head or sector invalid)
2Fh	Address overflow (address too large)
35h, 36h	Supply or generated voltage out of tolerance
11h	Uncorrectable ECC error
18h	Corrected ECC error
05h, 30-34h, 37h, 3Eh	Self test or diagnostic failed
10h, 14h	ID not found
3Ah	Spare sectors exhausted
1Fh	Data transfer error/aborted command
0Ch, 38h, 3Bh, 3Ch, 3Fh	Corrupted media format
03h	Write/erase failed

5.1.17 Seek—7XH

This command is effectively a NOP command to the card, although it does perform a range check of cylinder and head or LBA address and returns an error if the address is out of range.

Table 60: Seek

Bit	7	6	5	4	3	2	1	0
Command (7)	7XH							
C/D/H (6)	1	LBA	1	Drive	Head (LBA 27-24)			
Cyl High (5)	Cylinder High (LBA 23-16)							
Cyl Low (4)	Cylinder Low (LBA 15-8)							
Sec Num (3)	Sector Number (LBA 7-0)							
Sec Cnt (2)	X							
Feature (1)	X							

5.1.18 Set Features—EFH

The host uses this command to establish or select certain features.

Table 61: Set Features

Bit	7	6	5	4	3	2	1	0
Command (7)	EFH							
C/D/H (6)		X		Drive			X	
Cyl High (5)					X			
Cyl Low (4)					X			
Sec Num (3)					X			
Sec Cnt (2)						Config		
Feature (1)								Feature

Table 62 defines all supported features. The 9AH feature is unique to CompactFlash Memory cards and is not part of the ATA Specification.

Table 62: Features Supported

Feature	Operation
01h	Enable 8-bit data transfer
02h	Enable Write Cache
03h	Set Transfer Mode based on value and Sector Count register.
55h	Disable Read Look Ahead
66h	Disable Power on Reset (POR) establishment of defaults at Soft Reset
69h	Accepted for backward compatibility with the SDP Series but has no impact on the CF Memory Card.
81h	Disable 8-bit data transfer
96h	Accepted for backward compatibility with the SDP Series but has no impact on the CF Memory Card
9Ah	Accepted for backward compatibility with the SDP Series but has no impact on the CF Memory Card
BBh	4 bytes of data apply on Read/Write Long commands
CCh	Enable Power on Reset (POR) establishment of defaults at Soft Reset.

Features 01H and 81H are used to enable and disable 8-bit data transfer mode. If the 01H feature command is issued, all data transfers will occur on the low order D7-D0 data bus and the IOIS16 signal will not be asserted for data register accesses.

A host can choose the transfer mechanism by Set Transfer Mode and specifying a value in the Sector Count register. The upper 5 bits define the type of transfer and the low order 3 bits encode the mode value.

Mode	Value
PIO Default Transfer Mode	00000 00d
PIO Flow Control Transfer Mode x	00001 nnn
Multiword DMA Mode x	00100 nnn
Reserved	01000 nnn
Reserved	10000 nnn

Where “nnn” is a valid mode number in binary; “x” is the mode number in decimal for the associated transfer type; and “d” is ignored.

Features 55H and BBH are the default features for CompactFlash cards; thus the host does not have to issue this command with these features unless it is necessary for compatibility reasons.

The 9AH Feature is accepted for backward compatibility with the SDP Series but has no impact on the card. SanDisk does not recommend the use of this command in new designs.

Features 66H and CCH can be used define whether or not the Power On Reset (POR) Defaults will be set when a soft reset occurs. The default setting is to revert to the POR defaults when a soft reset occurs. POR defaults the number of heads and sectors, along with 16 bit data transfers and the read/write multiple block count.

5.1.19 Set Multiple Mode—C6H

This command enables the card to perform multiple Read and Write operations and establishes the block count for these commands. The Sector Count Register is loaded with the number of sectors per block. The current version of the card supports only a block size of 1 sector per block. Future versions may support larger block sizes. Upon receipt of the command, the card sets BSY to 1 and checks the Sector Count Register.

If the Sector Count Register contains a valid value and the block count is supported, the value is loaded for all subsequent Read Multiple and Write Multiple commands and execution of those commands is enabled. If a block count is not supported, an Aborted Command error is posted, and Read Multiple and Write Multiple commands are disabled. If the Sector Count Register contains 0 when the command is issued, Read and Write Multiple commands are disabled. At power on, or after a hardware or (unless disabled by a Set Feature command) software reset, the default mode is Read and Write Multiple disabled.

Table 63: Set MultipleMode

Bit	7	6	5	4	3	2	1	0
Command (7)	C6H							
C/D/H (6)		X		Drive			X	
Cyl High (5)					X			
Cyl Low (4)					X			
Sec Num (3)					X			
Sec Cnt (2)						Sector Count		
Feature (1)								X

5.1.20 Set Sleep Mode—99H, E6H

This command causes the card to set BSY, enter Sleep mode, clear BSY and generate an interrupt. Recovery from sleep mode is accomplished by simply issuing another command (a reset is permitted but not required). Sleep mode is also entered when internal timers expire, therefore the host does not need to issue this command unless it wishes to enter Sleep mode immediately. The default value for the read to sleep timer is 5 milliseconds. This time base (5 msec) is different from the ATA Specification.

Table 64: Set Multiple Mode

Bit	7	6	5	4	3	2	1	0
Command (7)	99H or E6H							
C/D/H (6)	X			Drive		X		
Cyl High (5)				X				
Cyl Low (4)				X				
Sec Num (3)				X				
Sec Cnt (2)				X				
Feature (1)				X				

5.1.21 Standby–96H, E2H

This command causes the card to set BSY, enter Sleep mode (which corresponds to the ATA "Standby" Mode), clear BSY and return the interrupt immediately. Recovery from sleep mode is accomplished by simply issuing another command (reset is not required).

Table 65: Standby

Bit	7	6	5	4	3	2	1	0
Command (7)	E2H or 96H							
C/D/H (6)	X			Drive		X		
Cyl High (5)				X				
Cyl Low (4)				X				
Sec Num (3)				X				
Sec Cnt (2)				X				
Feature (1)				X				

5.1.22 Standby Immediate–94H, E0H

This command causes the card to set BSY, enter Sleep mode (which corresponds to the ATA "Standby" Mode), clear BSY and return the interrupt immediately. Recovery from sleep mode is accomplished by simply issuing another command (reset is not required).

Table 66: Standby Immediate

Bit	7	6	5	4	3	2	1	0
Command (7)	E0H or 94H							
C/D/H (6)	X			Drive		X		
Cyl High (5)				X				
Cyl Low (4)				X				
Sec Num (3)				X				
Sec Cnt (2)				X				
Feature (1)				X				

5.1.23 Translate Sector–87H

When this command is issued, the controller responds with a 512-byte buffer of information on the desired cylinder, head and sector with the actual Logical Address.

Table 67: Translate Sector

Bit	7	6	5	4	3	2	1	0
Command (7)	87H							
C/D/H (6)	1	LBA	1	Drive	Head (LBA 27-24)			
Cyl High (5)	Cylinder High (LBA 23-16)							
Cyl Low (4)	Cylinder Low (LBA 15-8)							
Sec Num (3)	Sector Number (LBA 7-0)							
Sec Cnt (2)	X							
Feature (1)	X							

Table 68 represents the information in the buffer. This command is unique to SanDisk CompactFlash Memory cards.

Table 68: Translate Sector Information

Address	Information
00	Head
01-02	Cylinder
03	Sector
04-07	LBA
08	Chip
09-0A	Block
0B	Page
0C-1FF	Reserved

5.1.24 Wear Level–F5H

This command is effectively a NOP command and only implemented for backward compatibility with earlier SanDisk SDP series products. The Sector Count Register will always be returned with a 00H indicating Wear Level is not needed.

Table 69: Wear Level

Bit	7	6	5	4	3	2	1	0
Command (7)	F5H							
C/D/H (6)	X	X	X	Drive	Flag			
Cyl High (5)	X							
Cyl Low (4)	X							
Sec Num (3)	X							
Sec Cnt (2)	Completion Status							
Feature (1)	X							

5.1.25 Write Buffer–E8H

The Write Buffer command enables the host to overwrite contents of the card's sector buffer with any data pattern desired. This command has the same protocol as the Write Sector(s) command and transfers 512 bytes.

Table 70: Write Buffer

Bit	7	6	5	4	3	2	1	0
Command (7)	E8H							
C/D/H (6)		X		Drive			X	
Cyl High (5)					X			
Cyl Low (4)					X			
Sec Num (3)					X			
Sec Cnt (2)					X			
Feature (1)					X			

5.1.26 Write DMA Command–CAH, CBH

The Write DMA command in Table 71 performs in a similar manner to WRITE SECTOR(S) except for the following:

The host initialized the DMA channel prior to issuing the command. Data transfers are qualified by DMARQ and are performed by the DMA channel.

The device issues only one interrupt per command to indicate that data transfer has terminated and status is available.

During the execution of a Write DMA command, the device provides status of the BSY bit or the DRQ bit until the command is completed.

Table 71: Write DMA Command

Bit	7	6	5	4	3	2	1	0
Command (7)	CAH or CBH							
C/D/H (6)	1	LBA	1	Drive		Head (LBA 27-24)		
Cyl High (5)	Cylinder High (LBA 23-16)							
Cyl Low (4)	Cylinder Low (LBA 15-8)							
Sec Num (3)	Sector Number (LBA 7-0)							
Sec Cnt (2)	Sector Count							
Feature (1)	X							

5.1.27 Write Long Sector–32H, 33H

This command is provided for compatibility purposes and is similar to the Write Sector(s) command except that it writes 516 bytes instead of 512 bytes. Only single sector Write Long operations are supported. The transfer consists of 512 bytes of data transferred in word mode followed by 4 bytes of ECC transferred in byte mode. Because of the unique nature of the solid-state CompactFlash Memory Card, it cannot use the four bytes of ECC transferred by the host. The card discards these four bytes and writes the sector with valid ECC fields. This command has the same protocol as the Write Sector(s) command.

Table 72: Write Long Sector

Bit	7	6	5	4	3	2	1	0
Command (7)	32H or 33H							
C/D/H (6)	1	LBA	1	Drive	Head (LBA 27-24)			
Cyl High (5)	Cylinder High (LBA 23-16)							
Cyl Low (4)	Cylinder Low (LBA 15-8)							
Sec Num (3)	Sector Number (LBA 7-0)							
Sec Cnt (2)	X							
Feature (1)	X							

5.1.28 Write Multiple Command—C5H

This command is similar to the Write Sectors command. The card sets BSY within 400 nsec of accepting the command. Interrupts are not presented on each sector but on the transfer of a block that contains the number of sectors defined by Set Multiple. Command execution is identical to the Write Sectors operation, except that the number of sectors defined by the Set Multiple command is transferred without intervening interrupts.

DRQ qualification of the transfer is required only at the start of the data block, not on each sector. The block count of sectors to be transferred without intervening interrupts is programmed by the Set Multiple Mode command, which must be executed prior to the Write Multiple command.

Table 73: Write Multiple Command

Bit	7	6	5	4	3	2	1	0
Command (7)	C5H							
C/D/H (6)	X	LBA	X	Drive	Head			
Cyl High (5)	Cylinder High							
Cyl Low (4)	Cylinder Low							
Sec Num (3)	Sector Number							
Sec Cnt (2)	Sector Count							
Feature (1)	X							

When the Write Multiple command is issued, the Sector Count Register contains the number of sectors (not the number of blocks or the block count) requested. If the number of requested sectors is not evenly divisible by the sector/block, as many full blocks as possible are transferred, followed by a final, partial block transfer. The partial block transfer is for n sectors, where: $n = \text{remainder}(\text{sector count}/\text{block count})$.

If the Write Multiple command is attempted before the Set Multiple Mode command has been executed or when Write Multiple commands are disabled, the Write Multiple operation will be rejected with an aborted command error.

Errors encountered during Write Multiple commands are posted after the attempted writes of the block or partial block transferred. The Write command ends with the sector in error, even if it is in the middle of a block. Subsequent blocks are not transferred in the event of an error. Interrupts are generated when DRQ is set at the beginning of each block or partial block.

The Command Block registers contain the cylinder, head and sector number of the sector where the error occurred and the Sector Count Register contains the residual number of sectors that need to be transferred for successful

completion of the command e.g., each block has 4 sectors, a request for 8 sectors is issued and an error occurs on the third sector. The Sector Count Register contains 6 and the address is that of the third sector.

5.1.29 Write Multiple without Erase—CDH

SanDisk does not recommend the use of this command in new designs but it is supported as a normal Write Sectors command for backward compatibility.

Table 74: Write Multiple w/out Erase

Bit	7	6	5	4	3	2	1	0
Command (7)	CDH							
C/D/H (6)	X	LBA	X	Drive	Head			
Cyl High (5)	Cylinder High							
Cyl Low (4)	Cylinder Low							
Sec Num (3)	Sector Number							
Sec Cnt (2)	Sector Count							
Feature (1)	X							

5.1.30 Write Sector(s)—30H, 31H

This command writes from 1 to 256 sectors as specified in the Sector Count Register. A sector count of zero requests 256 sectors. The transfer begins at the sector specified in the Sector Number Register. When this command is accepted, the card sets BSY, then sets DRQ and clears BSY, then waits for the host to fill the sector buffer with the data to be written. No interrupt is generated to start the first buffer fill operation. The host should not transmit any data until it has cleared BSY.

For multiple sectors, after the first sector of data is in the buffer, BSY will be set and DRQ will be cleared. After the next buffer is ready for data, BSY is cleared, DRQ is set and an interrupt is generated. When the final sector of data is transferred, BSY is set and DRQ is cleared. This state will be maintained until the command is completed, at which time BSY is cleared and an interrupt is generated.

If an error occurs during a write of more than one sector, writing terminates at the sector in which the error occurs. The Command Block registers contain the cylinder, head and sector number of the sector where the error occurred. The host may then read the command block to determine what error occurred, and on which sector.

Table 75: Write Sector(s)

Bit	7	6	5	4	3	2	1	0
Command (7)	30H or 31H							
C/D/H (6)	1	LBA	1	Drive	Head (LBA 27-24)			
Cyl High (5)	Cylinder High (LBA 23-16)							
Cyl Low (4)	Cylinder Low (LBA 15-8)							
Sec Num (3)	Sector Number (LBA 7-0)							
Sec Cnt (2)	Sector Count							
Feature (1)	X							

5.1.31 Write Sector(s) without Erase—38H

SanDisk does not recommend the use of this command in new designs, but it is supported as a normal Write Sectors command for backward compatibility.

Table 76: Write Sector(s) w/out Erase

Bit	7	6	5	4	3	2	1	0
Command (7)	38H							
C/D/H (6)	1	LBA	1	Drive	Head (LBA 27-24)			
Cyl High (5)	Cylinder High (LBA 23-16)							
Cyl Low (4)	Cylinder Low (LBA 15-8)							
Sec Num (3)	Sector Number (LBA 7-0)							
Sec Cnt (2)	Sector Count							
Feature (1)	X							

5.1.32 Write Verify Sector(s)—3CH

This command writes from 1 to 256 sectors as specified in the Sector Count Register. A sector count of zero requests 256 sectors. The transfer begins at the sector specified in the Sector Number Register. When this command is accepted, the card sets BSY, then sets DRQ and clears BSY, then waits for the host to fill the sector buffer with the data to be written. No interrupt is generated to start the first buffer fill operation. The host should not transmit any data until it has cleared BSY.

For multiple sectors, after the first sector of data is in the buffer, BSY will be set and DRQ will be cleared. After the next buffer is ready for data, BSY is cleared, DRQ is set and an interrupt is generated. When the final sector of data is transferred, BSY is set and DRQ is cleared. This state will be maintained until the command is completed, at which time BSY is cleared and an interrupt is generated.

Table 77: Write Verify Sectors

Bit	7	6	5	4	3	2	1	0
Command (7)	3CH							
C/D/H (6)	1	LBA	1	Drive	Head (LBA 27-24)			
Cyl High (5)	Cylinder High (LBA 23-16)							
Cyl Low (4)	Cylinder Low (LBA 15-8)							
Sec Num (3)	Sector Number (LBA 7-0)							
Sec Cnt (2)	Sector Count							
Feature (1)	X							

If an error occurs during a write of more than one sector, writing terminates at the sector where the error occurs. The Command Block registers contain the cylinder, head and sector number of the sector in which the error occurred. The host may then read the command block to determine what error occurred, and on which sector.

5.2 Error Posting

Table 78 summarizes the valid status and error value for all the ATA command set.

Table 78: Error and Status Registers

Command	Error Register					Status Register				
	BBK	UNC	IDNF	ABRT	AMNF	DRDY	DWF	DSC	CORR	ERR
Check Power Mode	-	-	-	√	-	√	√	√	-	√
Execute Drive Diagnostic	-	-	-	-	-	√	-	√	-	√
Erase Sector(s)	√	-	√	√	√	√	√	√	-	√
Format Track	-	-	√	√	√	√	√	√	-	√
Identify Device	-	-	-	√	-	√	√	√	-	√
Idle	-	-	-	√	-	√	√	√	-	√
Idle Immediate	-	-	-	√	-	√	√	√	-	√
Initialize Drive Parameters	-	-	-	-	-	√	-	√	-	√
Read Buffer	-	-	-	√	-	√	√	√	-	√
Read DMA ^b	√	√	√	√	√	√	√	√	√	√
Read Multiple	√	√	√	√	√	√	√	√	√	√
Read Long Sector	√	-√	√	√	√	√	√	√	-	√
Read Sector(s)	√	√	√	√	√	√	√	√	√	√
Read Verify Sectors	√	√	√	√	√	√	√	√	√	√
Recalibrate	-	-	-	√	-	√	√	√	-	√
Request Sense	-	-	-	√	-	√	-	√	-	√
Seek	-	-	√	√	-	√	√	√	-	√
Set Features	-	-	-	√	-	√	√	√	-	√
Set Multiple Mode	-	-	-	√	-	√	√	√	-	√
Set Sleep Mode	-	-	-	√	-	√	√	√	-	√
Standby	-	-	-	√	-	√	√	√	-	√
Standby Immediate	-	-	-	√	-	√	√	√	-	√
Translate Sector	√	-	√	√	√	√	√	√	-	√
Wear Level	√	√	√	√	√	√	√	√	-	√
Write Buffer	-	-	-	√	-	√	√	√	-	√
Write DMA	√	-	√	√	-	√	√	-	-	√
Write Long Sector	√	-	√	√	√	√	√	√	-	√
Write Multiple	√	-	√	√	√	√	√	√	-	√
Write Multiple w/o Erase	√	-	√	√	√	√	√	√	-	√
Write Sector(s)	√	-	√	√	√	√	√	√	-	√
Write Sector(s) w/o Erase	√	-	√	√	√	√	√	√	-	√
Write Verify Sector(s)	√	-	√	√	√	√	√	√	-	√
Invalid Command Code	-	-	-	√	-	√	√	√	-	√

a. √ = Valid on this command.

b. CompactFlash products support multiword DMA.

6. CIS Description

This section describes the Card Information Structure (CIS) for SanDisk CompactFlash Memory cards.

Table 79: Card Information Structure

Attribute Offset	Data	7	6	5	4	3	2	1	0	Content Description	CIS Function
000h	01h	CISTPL_DEVICE								Device Info Tuple	Tuple Code
002h	04h									Link is 4 bytes	Link to next tuple
004h	DFh	Dev ID Type Dh = I/O				W 1	Speed 7h = Ext			I/O Device, Wait State, Extended Speed	Device ID, WPS, Speed
006h	12h	X	Speed Mantissa = 2h			Speed Exponent = 2h			120 ns if no wait	Extended Speed	
	79h Extreme III	X	Speed Mantissa = Fh			Speed Exponent = 1h			80 ns if no wait	Extended Speed	
008h	01h	# Address Unit - 1 = 1x				Side Code = 2k units			(One) 2 kB of Address Space	Device Size	
00Ah	FFh	List End Marker								End of Devices	End Marker
00Ch	1Ch	CISTPL_DEVICE_OC								Other Conditions Info Tuple	Tuple Code
00Eh	04h									Link is 4 Bytes	Link to Next Tuple
010h	03h	Reserved = 0				Vcc	W A I T		Conditions: 3V operation is allowed and WAIT is used	3 V Operation, Wait Function	
012h	D9h	Dev ID Type Dh = I/O			W 1	Speed = 1h			I/O Device, WPS, Speed = 250 ns	Device ID, WPS, Speed	
014h	01h	# Address Unit - 1 = 1x				Side Code = 2k units			2 kB of Address Space	Device Size	
016h	FFh	List End Marker								End of Devices	End Marker
018h	18h	CISTPL_JEDEC_C								JEDEC ID Common Memory	Tuple Code
01Ah	02h									Link is 2 bytes	Link Length
01Ch	DFh	PCMCIA JEDEC Manufacturer's ID								First byte of JEDEC ID for SanDisk PC Card ATA 12V	Byte 1, JEDEC ID of Device 1 (0-2K)
01Eh	01h	PCMCIA Code for PC Card-ATA No Vpp Required								Second Byte of JEDEC ID	Byte 2, JEDEC ID
020h	20h	CISTPL_MANFID								Manufacturer's ID Tuple	Tuple Code
022h	04h									Link is 4 bytes	Link Length
024h	45h	Low Byte of PCMCIA Manufacturer's Code								SanDisk JEDEC Manufacturer's ID	Low Byte of PCMCIA Mfg ID
026h	00h	High Byte of PCMCIA Manufacturer's Code								Code of 0 because other byte is JEDEC 1 byte Manufacturer's ID	High Byte of PCMCIA Mfg ID
028h	01h	Low Byte of Product Code								SanDisk Code for SDP Series	Low Byte Product Code
02Ah	04h	High Byte of Product Code								SanDisk Code for PC Card ATA	High Byte Product Code

Attribute Offset	Data	7	6	5	4	3	2	1	0	Content Description	CIS Function
02Ch	15h	CISTPL_VER_1								Level 1 Version/Product Info	Tuple Code
02Eh	17h									Link to next tuple is 23 bytes	Link Length
030h	04h	TPPLV1_MAJOR								PCMCIA 2.0/JEIDA 4.1	Major Version
032h	01h	TPPLV1_MINOR								PCMCIA 2.0/JEIDA 4.1	Minor Version
034h	53h	ASCII Manufacturer String								'S'	String 1
036h	61h									'a'	
038h	6Eh									'n'	
03Ah	44h									'D'	
03Ch	69h									'i'	
03Eh	73h									's'	
040h	6Bh									'k'	
042h	00h	End of Manufacturer String								Null Terminator	
044h	53h	ASCII Product Name String								'S'	Info String 2
046h	44h									'D'	
048h	50h									'P'	
04Ah	00h	End of Product Name String								Null Terminator	
04Ch	35h									'5'	Info String 3
04Eh	2Fh									'/'	
050h	33h									'3'	
052h	20h									''	
054h	30h	SanDisk Card CIS Revision Number								'0'	
056h	2Eh									':'	
058h	36h									'6'	
05Ah	00h	End of CIS Revision Number								Null Terminator	
05Ch	FFh	End of List Marker								FFh List Terminator	No Info String 4
05Eh	80h	CISTPL_VEND_SPECIF_80								SanDisk Parameters Tuple	Tuple Code
060h	03h	(Field Bytes 3-4 taken as 0)								Link Length is 3 Bytes	Link to Next Tuple and Length of Info in this Tuple
062h	14h	W	12	NI	PP	P D N A 0	RI A	RI R	SP	No Wear Level & NO Vpp W: No Wear Level 12: Vpp not used on Write NI: -INPACK connected PP: Programmable Power PDNA: Pwr Down Not Abort--Cmd RIA: RBsy, ATBsy connected	SanDisk Fields, 1 to 4 Bytes limited by link length

Attribute Offset	Data	7	6	5	4	3	2	1	0	Content Description	CIS Function
										<p>RIR: RBsy Inhibited at Reset</p> <p>SP: No Security Present This definition applies only to cards with Manufacturer's ID tuple 1st 3 bytes 45 00 01.</p>	
064h	08h	R 0	R 0	R 0	R 0	E 1	TPR 0	TAR 0	R8 0	<p>R8: 8 bit ROM present</p> <p>TAR: Temp Bsy on AT Reset</p> <p>TPR: Temp Bsy on PCMCIA – Reset</p> <p>E: Erase Ahead Available</p> <p>R: Reserved, 0 for now This definition applies only to cards with Manufacturer's ID tuple 1st 3 bytes 45 00 01.</p>	SanDisk Fields, 1 to 4 bytes limited by link length
066h	00h										For specific platform use only
068h	21h	CISTPL_FUNCID								Function ID Tuple	Tuple Code
06Ah	02h									Link Length is 2 Bytes	Link to Next Tuple
06Ch	04h	Function Type Code								Disk Function	Function Code
06Eh	01h	R 0	R 0	R 0	R 0	R 0	R 0	R 0	P 1	<p>Attempt installation at POST:</p> <p>P: Install at POST</p> <p>R: Reserved (0)</p>	
070h	22h	CISTPL_FUNCCE								Function Extension Tuple	Tuple Code
072h	02h									Link Length is 2 Bytes	Link to Next Tuple
074h	01h	Disk Function Extension Tuple Type								Extension Tuple describes the Interface Protocol	Extension Tuple Type for Disk
076h	01h	Interface Type Code								PC Card–ATA Interface	Extension Info
078h	22h	CISTPL_FUNCCE								Function Extension tuple	Tuple Code
07Ah	03h									Tuple has 3 Info Bytes	Link Length
07Ch	02h	Disk Function Extension Tuple Type								Basic PCMCIA-ATA Extension Tuple	Extension Tuple Type for Disk

Attribute Offset	Data	7	6	5	4	3	2	1	0	Content Description	CIS Function
07Eh	0Ch	R 0	R 0	R 0	R 0	U 1	S 1	V 0		Unique Manufacturer/ Serial Number combined string: V = 0: No Vpp Required V = 1: Vpp on Modified Media V = 2: Vpp on Any Operation V = 3: Vpp Continuous S: Silicon, else Rotating Drive U: ID Drive Mfg/SN Unique	Basic ATA Option Parameters
080h	0Fh	R 0	I 0	E 0	N 0	P3 1	P2 1	P1 1	P0 1	All power-down modes and power commands are not needed to minimize power. P0: Sleep Mode Supported P1: Standby Mode Supported P2: Idle Mode Supported P3: Drive Auto Power Control N: Some Config Excludes 3X7 E: Index Bit is Emulated I: Twin--IOis16 Data Reg Only	Extended ATA Option Parameters
082h	1Ah	CISTPL_CONF								Configuration Tuple	Tuple Code
084h	05h									Link Length is 5 Bytes	Link to Next Tuple
086h	01h	RFS 00			RMS 00		RAS 01			Size of Reserved Field is 0 Bytes Size of Register Mask is 1 Byte Size of Config Base Address is 2 Bytes RFS: Bytes in Reserved Field RMS: Bytes in Reg Mask-1 RAS: Bytes in Base Addr-1	Size of Fields Byte (TPCC_SZ)
088h	07h	TPCC_LAST								Entry with Config Index 07h is final entry in table	Last Entry of Config. Table
08Ah	00h	TPCC_RADR (LSB)								Configuration Registers located at 200h in Reg. Space	Location of Config. Registers
02h		TPCC_RADR (MSB)									

Attribute Offset	Data	7	6	5	4	3	2	1	0	Content Description	CIS Function	
08Eh	0Fh	R 0	R 0	R 0	R 0	S 1	P 1	C 1	I 1	First (4) Configuration Registers are present:	TPCC_RMSK	
										I: Configuration Index C: Configuration and Status P: Pin Replacement S: Socket and Copy R: Reserved for future use		
090h	1Bh	CISTPL_CE								Configuration Entry Tuple	Tuple Code	
092h	0Bh									Link to Next Tuple is 11 Bytes. Also limits size of this tuple to 13 bytes.	Link to Next Tuple	
094h	C0h	I 1	D 1	Configuration Index 0							Memory Mapped I/O Configuration Configuration Index for this entry is 0. Interface Byte follows this byte. Default Configuration, so is not dependent on previous Default Configuration. D: Default Configuration I: Interface Byte follows	TPCE_INDX
096h	C0h	W 1	R 1	P 0	B 0	Interface Type				Memory Only Interface(0), Bvd's and wProt not used, Ready/-Busy and Wait for memory cycles active. B: Battery Volt Detects Used P: Write Protect Used R: Ready/-Busy Used W: Wait Used for Memory Cycles	TPCE_IF	
098h	A1h	M 1	MS 1	IR 0	IO 0	T 0	P 1			Vcc only Power; No Timing, I/O, or IRQ; 2 Byte Memory Space Length; Misc Entry Present. P: Power Info type T: Timin Info present IO :I/O Port Info present IR: Interrupt Info present MS: Mem Space Info	TPCE_FS	

Attribute Offset	Data	7	6	5	4	3	2	1	0	Content Description	CIS Function
										type M: Misc Info Byte(s) present	
09Ah	27h	R 0	DI 0	PI 1	AI 0	SI 0	HV 1	LV 1	NV 1	Nominal Voltage follows: NV: Nominal Voltage LV: Minimum Voltage	Power Parameters for Vcc
										HB: Maximum Voltage SI: Static Current AI: Average Current PI: Peak Current DI: Power Down Current	
09Ch	55h	X 0	Mantissa Ah = 5.0			Exponent 5h = 1V				Vcc Nominal is 5 V	Vcc Nominal Value
09Eh	4Dh	X 0	Mantissa 9h = 4.5			Exponent 5h = 1V				Vcc Nominal is 4.5 V	Vcc Min. Value
0A0h	5Dh	X 0	Mantissa Bh = 5.5			Exponent 5h = 1V				Vcc Nominal is 5.5 V	Vcc Max. Value
0A2h	75h	X 0	Mantissa Eh = 8.0			Exponent 5h = 10				Max. Average Current over 10 ms is 80 mA	Max. Average Current
0A4h	08h	Length in 256 Bytes Pages (LSB)								Length of Memory Space is 2 kB	TPCE_MS Length LSB
0A6h	00h	Length in 256 Bytes Pages (MSB)								Start at 0 on card	TPCE_MS Length MSB
0A8h	21h	X 0	R 0	P 1	RO 0	A 0	T 1			Power-Down and Twin Card. T: Twin Cards Allowed A: Audio Supported RO: Read Only Mode P: Power Down Supported R: Reserved X: More Miscellaneous Fields Bytes	TPCE_MI
0AAh	1Bh	CISTPL_CE								Configuration Entry Tuple	Tuple Code
0ACh	06h									Link to Next Tuple is 6 Bytes. Also limits size of this tuple to 8 bytes.	Link to Next Tuple
0AEh	00h	I 0	D 0	Configuration Index 0						Memory Mapped I/O 3.3V Configuration.	TPCE_INDX
0B0h	01h	M 0	MS 0		IR 0	IO 0	T 0	P 1		P: Power Info type	TPCE_FS
0B2h	21h	R 0	DI 0	PI 1	AI 0	SI 0	H 0	LV 0	NV 1	PI: Peak Current NV: Nominal Operation Supply Voltage	TPCE_PD

Attribute Offset	Data	7	6	5	4	3	2	1	0	Content Description	CIS Function		
0B4h	B5h	X 1	Mantissa 6h = 3.0				Exponent 5h = 10			Nominal Operation Supply Voltage = 3.0V	Nominal Operation Supply Voltage		
0B6h	1Eh	X 0	1Eh									+ .30	Nominal Operation Supply Voltage Extension Byte
0B8h	4Dh	X 0	Mantissa 9h = 4.5				Exponent 5h = 10			Max. Average Current over 10 ms is 45 mA	Max. Average Current		
0BAh	1Bh	CISTPL_CE								Configuration Entry Tuple	Tuple Code		
0BCh	0Dh	Link to Next Tuple is 13 Bytes. Also limits size of this tuple to 15 bytes.									Link to Next Tuple		
0BEh	C1h	I 1	D 1	Configuration Index 1							I/O Mapped Contiguous 16 Registers Configuration. Configuration Index for this entry is 1. Interface Byte follows this byte. Default Configuration, therefore is not dependent on previous Default Configuration. D: Default Configuration I: Interface Byte follows	TPCE_INDX	
0C0h	41h	W 0	R 1	P 0	B 0	Interface Type 1				I/O Interface(1), Bvd's and wProt not used; Ready/-Busy active but Wait not used for memory cycles. B: Battery Volt Detects Used P: Write Protect Used R: Ready/-Busy Used W: Wait Used for Memory Cycles	TPCE_IF		
0C2h	99h	M 1	MS 0	IR 1	IO 1	T 0	P 1				Vcc Only Power Descriptors; No Timing; I/O and IRQ present; No Memory Space; Misc Entry Present P: Power Info type T: Timing Info present IO :I/O Port Info present IR: Interrupt Info present MS: Memory Space Info type	TPCE_FS	

Attribute Offset	Data	7	6	5	4	3	2	1	0	Content Description	CIS Function
										M: Misc Info Byte(s) present	
0C4h	27h	R 0	DI 0	PI 1	AI 0	SI 0	HV 1	LV 1	NV 1	Nominal Voltage Follows NV: Nominal Voltage LV: Minimum Voltage HB: Maximum Voltage SI: Static Current AI: Average Current	Power Parameters for Vcc
										PI: Peak Current DI: Power Down Current	
0C6h	55h	X 0	Mantissa Ah = 5.0				Exponent 5h = 1V			Vcc Nominal is 5V	Vcc Nominal Value
0C8h	4Dh	X 0	Mantissa 9h = 4.5				Exponent 5h = 1V			Vcc Nominal is 4.5V	Vcc Min. Value
0CAh	5Dh	X 0	Mantissa Bh = 5.5				Exponent 5h = 1V			Vcc Nominal is 5.5V	Vcc Max. Value
0CCh	75h	X 0	Mantissa Eh = 8.0				Exponent 5h = 10			Max. Average Current over 10 ms is 80 mA	Max. Average Current
0CEh	64h	R 0	S 1	E 1	IO AddrLines 4					Supports both 8 and 16 bit I/O hosts. 4 Address lines & no range so 16 registers and host must do all of the selection decoding. IO AddrLines:#lines decoded. E: 8-bit Only Hosts Supported S: 16-bit Hosts Supported R: Range follows	TPCE_IO
0D0h	F0h	S 1	P 1	L 1	M 1	V 0	B 0	I 0	N 0	IRQ Sharing Logic Active in Card Control & Status Register, Pulse and Level Mode Interrupts supported, Recommended IRQ's any of 0 through 15(F) S: Share Logic Active P: Pulse Mode IRQ Supported L: Level Mode IRQ Supported M: Bit Mask of IRQs Present V: Vendor Unique IRQ B: Bus Error IRQ	TPCE_IR

Attribute Offset	Data	7	6	5	4	3	2	1	0	Content Description	CIS Function	
										I: IO Check IRQ N: Non-Maskable IRQ		
0D2h	FFh	7 1	6 1	5 1	4 1	3 1	2 1	1 1	0 1	IRQ Levels to be routed 0 - 15 recommended.	TPCE_IR Mask Extension Byte 1	
0D4h	FFh	F 1	E 1	D 1	C 1	B 1	A 1	9 1	8 1	Recommended routing to any "normal, maskable" IRQ.	TPCE_IR Mask Extension Byte 2	
0D6h	21h	X 0	R 0	P 1	RO 0	A 0	T 1			Power-Down and Twin Card. T: Twin Cards Allowed A: Audio Supported RO: Read Only Mode P: Power Down Supported R: Reserved X: More Misc Fields Bytes	TPCE_MI	
0D8h	1Bh	CISTPL_CE								Configuration Entry Tuple	Tuple Code	
0DAh	06h									Link to Next Tuple is 6 Bytes. Also limits size of this tuple to 8 bytes.	Link to Next Tuple	
0DCh	01h	I 0	D 0	Configuration Index 1							I/O Mapped Contiguous 16 3.3V Configuration	TPCE_INDX
0DEh	01h	M 0	MS 0	IR 0	IO 0	T 0	P 1			P: Power Info type	TPCE_FS	
0E0h	21h	R 0	DI 0	PI 1	AI 0	SI 0	HV 0	LV 0	NV 1	PI: Peak Current NV: Nominal Operation Supply Voltage	Power Parameters for Vcc	
0E2h	B5h	X 1	Mantissa 6h = 3.0				Exponent 5h = 1			Nominal Operation Supply Voltage = 3.0V	Nominal Operation Supply Voltage	
0E4h	1Eh	X 0	1Eh							+30	Nominal Operation Supply Voltage Extension Byte	
0E6h	4Dh	X 0	Mantissa 9h = 4.5				Exponent 5h = 10			Max. Average Current over 10 ms is 45 mA	Max. Average Current	
0E8h	1Bh	CISTPL_CE								Configuration Entry Tuple	Tuple Code	

Attribute Offset	Data	7	6	5	4	3	2	1	0	Content Description	CIS Function
0EAh	12h									Link to Next Tuple is 18 Bytes. Also limits size of this tuple to 20 bytes	Link to Next Tuple
0ECh	C2h	I 1	D 1	Configuration Index 2						AT Fixed Disk Primary I/O Address Configuration Configuration Index for this entry is 2. Interface Byte follows this byte. Default Configuration	TPCE_INDX
0EEh	41h	W 0	R 1	P 0	B 0	Interface Type 1			I/O Interface(1), Bvd's and wProt not used; Ready/-Busy active but Wait not used for memory cycles. B: Battery Volt Detects Used P: Write Protect Used R: Ready/-Busy Used W: Wait Used for Memory Cycles	TPCE_IF	
0F0h	99h	M 1	MS 0		IR 1	IO 1	T 0	P 1		Vcc Only Power Description: No Timing; I/O and IRQ present; No Memory Space; Misc Entry present. P: Power Info type T: Timing Info present IO: I/O Port Info present IR: Interrupt Info present MS: Memory Space Info type M: Misc Info Byte(s) present	TPCE_FS
0F2h	27h	R 0	DI 0	PI 1	AI 0	SI 0	HV 1	LV 1	NV 1	Nominal Voltage follows: NV: Nominal Voltage LV: Minimum Voltage HB: Maximum Voltage SI: Static Current AI: Average Current PI: Peak Current DI: Power Down Current	Power Parameters for Vcc
0F4h	55h	X 0	Mantissa Ah = 5.0				Exponent 5h = 1V			Vcc Nominal is 5V	Vcc Nominal Value
0F6h	4Dh	X 0	Mantissa 9h = 4.5				Exponent 5h = 1V			Vcc Nominal is 4.5V	Vcc Min. Value

Attribute Offset	Data	7	6	5	4	3	2	1	0	Content Description	CIS Function	
0F8h	5Dh	X 0	Mantissa Bh = 5.5			Exponent 5h = 1V			Vcc Nominal is 5.5V	Vcc Max. Value		
0FAh	75h	X 0	Mantissa 9h = 4.5			Exponent 5h = 10			Max. Average Current over 10 ms is 80 mA	Max. Average Current		
0FCH	EAh	R 1	S 1	E 1	IO AddrLines Ah = 10					Supports both 8- and 16-bit I/O hosts. 10 Address Lines with range so card will respond only to indicated (1F0-1F7, 3F6-3F7) on A9 through A0 for I/O cycles. IO AddrLines:#lines decoded E: 8-bit Only Hosts Supported S: 16-bit Hosts Supported R: Range follows	TPCE_IO	
0FEh	61h	LS 1		AS 2		N Ranges - 1 1					Number of Ranges is 2; Size of each address is 2 bytes; size of each length is 1 byte. AS: Size of Addresses 0: No Address Present 1: 1Byte (8 bit) Addresses 2: 2Byte (16 bit) Addresses 3: 4Byte (32 bit) Addresses LS: Size of length 0: No Lengths Present 1: 1Byte (8 bit) Lengths 2: 2Byte (16 bit) Lengths 3: 4Byte (32 bit) Lengths	I/O Range Format Description
100h	F0h	1st I/O Base Address (lsb)								First I/O Range Base is 1F0h		
01h		1st I/O Base Address (msb)										
104h	07h	1st I/O Range Length - 1								8 Bytes Total ==> 1F0-1F7h	I/O Length-1	
106h	F6h	2nd I/O Base Address (lsb)								2nd I/O Range Base is 3F6h		
03h		2nd I/O Base Address (msb)										
10Ah	01h	2nd I/O Range Length - 1								2 Bytes Total ==> 3F6-3F7h	I/O Length-1	

Attribute Offset	Data	7	6	5	4	3	2	1	0	Content Description	CIS Function	
10Ch	Eh	S 1	P 1	L 1	M 0	Recommend IRQ Level Eh = 14				IRQ Sharing Logic Active in Card Control & Status Register, Pulse and Level Mode Interrupts supported, Recommended IRQ's any of 0 through 15(F) S: Share Logic Active P: Pulse Mode IRQ Supported L: Level Mode IRQ Supported M: Bit Mask of IRQs Present M=0 so bits 3-0 are single level, binary encoded	TPCE_IR	
10Eh	21h	X 0	R 0	P 1	RO 0	A 0	T 1			Power-Down and Twin Card. T: Twin Cards Allowed A: Audio Supported RO: Read Only Mode P: Power Down Supported R: Reserved X: More Misc Fields Bytes	TPCE_MI	
110h	1Bh	CISTPL_CE								Configuration Entry Tuple	Tuple Code	
112h	06h									Link to Next Tuple is 6 Bytes. Also limits size of this tuple to 8 bytes.	Link to Next Tuple	
114h	02h	I 0	D 0	Configuration Index 2							AT Fixed Disk Primary I/O 3.3V Configuration	TPCE_INDX
116h	01h	M 0	MS 0	IR 0	IO 0	T 0	P 1				P: Power Info type	TPCE_FS
118h	21h	R 0	DI 0	PI 1	AI 0	SI 0	HV 0	LV 0	NV 1	PI: Peak Current NV: Nominal Operation Supply Voltage	Power Parameters for Vcc	
11AH	B5h	X 1	Mantissa 6h = 3.0				Exponent 5h = 1			Nominal Operation Supply Voltage = 3.0V	Nominal Operation Supply Voltage	

Attribute Offset	Data	7	6	5	4	3	2	1	0	Content Description	CIS Function		
11Ch	1Eh	X 0	1Eh							+30	Nominal Operation Supply Voltage Extension Byte		
11Eh	4Dh	X 0	Mantissa 9h = 4.5				Exponent 5h = 10			Max. Average Current over 10 ms is 45 mA	Max. Average Current		
120h	1Bh	CISTPL_CE								Configuration Entry Tuple	Tuple Code		
122h	12h									Link to Next Tuple is 18 Bytes. Also limits size of this tuple to 20 bytes.	Link to Next Tuple		
124h	C3h	I 1	D 1	Configuration Index 3								AT Fixed Disk Secondary I/O Address Configuration Configuration Index for this entry is 3. Interface Byte follows this byte. Default Configuration	TPCE_INDX
126h	41h	W 0	R 1	P 0	B 0	Interface Type 1					I/O Interface(1), Bvd's and wProt not used; Ready/ Busy active but Wait not used for memory cycles. B: Battery Volt Detects Used P: Write Protect Used R: Ready/-Busy Used W: Wait Used for Memory Cycles	TPCE_IF	
128h	99h	M 1	MS 0	IR 1	IO 1	T 0	P 1				Vcc-Only Power Descriptors; No Timing; I/O and IRQ present; No Memory Space; Misc Entry Present. P: Power Info type T: Timing Info present IO: I/O Port Info present IR: Interrupt Info present MS: Memory Space Info type M: Misc Info Byte(s) present	TPCE_FS	
12Ah	27h	R 0	DI 0	PI 1	AI 0	SI 0	HV 1	LV 1	NV 1	Nominal Voltage Follows NV: Nominal Voltage LV: Minimum Voltage HB: Maximum Voltage SI: Static Current	Power Parameters for Vcc		

Attribute Offset	Data	7	6	5	4	3	2	1	0	Content Description	CIS Function	
										AI: Average Current PI: Peak Current DI: Power Down Current		
12Ch	55h	X 0	Mantissa Ah = 5.0			Exponent 5h = 1V			Vcc Nominal is 5V	Vcc Nominal Value		
12Eh	4Dh	X 0	Mantissa 9h = 4.5			Exponent 5h = 1V			Vcc Nominal is 4.5V	Vcc Min. Value		
130h	5Dh	X 0	Mantissa Bh = 5.5			Exponent 5h = 1V			Vcc Nominal is 5.5V	Vcc Max. Value		
132h	75h	X 0	Mantissa Eh = 1.0			Exponent 5h = 10			Max. Average Current over 10 ms is 80 mA	Max. Average Current		
134h	EAh	R 1	S 1	E 1	IO AddrLines Ah = 10					Supports both 8- and 16-bit I/O hosts. 10 Address Lines with Range so card will respond only to indicated (170-177, 376377) on A9 through A0 for I/O cycles. IO AddrLines:#lines decoded E: 8-bit Only Hosts Supported S: 16-bit Hosts Supported R: Range follows	TPCE_IO	
136h	61h	LS 1		AS 2		N Ranges-1 1					Number of Ranges is 2; Size of each address is 2 bytes; size of each length is 1 byte. AS: Size of Addresses 0: No Address Present 1: 1Byte (8 bit) Addresses 2: 2Byte (16 bit) Addresses 3: 4Byte (32 bit) Addresses LS: Size of length 0: No Lengths Present 1: 1Byte (8 bit) Lengths 2: 2Byte (16 bit) Lengths 3: 4Byte (32 bit) Lengths	I/O Range Format Description
138h	70h	1st I/O Base Address (LSB)								First I/O Range Base is 170h		
01h		1st I/O Base Address (MSB)										
13Ch	07h	1st I/O Range Length-1								8 Bytes Total ==> 170-177h	I/O Length-1	

Attribute Offset	Data	7	6	5	4	3	2	1	0	Content Description	CIS Function		
13Eh	76h	2nd I/O Base Address (LSB)								Second I/O Range Base is 376h			
142h	01h	2nd I/O Range Length-1								2 Bytes Total ==> 376-377h	I/O Length-1		
144h	Eh	S 1	P 1	L 1	M 0	Recommend IRQ Level Eh = 14					IRQ Sharing Logic Active in Card Control & Status Register, Pulse and Level Mode Interrupts supported, Recommended IRQ's any of 0 through 15(F). S: Share Logic Active P: Pulse Mode IRQ Supported L: Level Mode IRQ Supported M: Bit Mask of IRQs Present M=0 therefore bits 3-0 are single level, binary encoded	TPCE_IR	
146h	21h	X 0	R 0	P 1	RO 0	A 0	T 1			Power-Down, and Twin Card. T: Twin Cards Allowed A: Audio Supported RO: Read Only Mode P: Power Down Supported R: Reserved X: More Misc Fields Bytes	TPCE_MI		
148h	1Bh	CISTPL_CE								Configuration Entry Tuple	Tuple Code		
14Ah	06h									Link to Next Tuple is 6 Bytes. Also limits size of this tuple to 8 bytes.	Link to Next Tuple		
14Ch	03h	I 0	D 0	Configuration Index 3								AT Fixed Disk Secondary I/O 3.3V Configuration	TPCE_INDX
14Eh	01h	M 0	MS 0		IR 0	IO 0	T 0	P 1			P: Power Info type	TPCE_FS	
150h	21h	R 0	DI 0	PI 1	AI 0	SI 0	HV 0	LV 0	NV 1	PI: Peak Current NV: Nominal Operation Supply Voltage	Power Parameters for Vcc		
152h	B5h	X 1	Mantissa 6h = 3.0				Exponent 5h = 1			Nominal Operation Supply Voltage = 3.0V	Nominal Operation Supply Voltage		

Attribute Offset	Data	7	6	5	4	3	2	1	0	Content Description	CIS Function	
154h	1Eh	X 0	1Eh							0.3	Nominal Operation Supply Voltage Extension Byte	
156h	4Dh	X 0	Mantissa 9h = 4.5				Exponent 5h = 10			Max. Average Current over 10 ms is 45 mA	Max. Average Current	
158H	1Bh	CISTPL_CE								Configuration Entry Tuple	Tuple Code	
15Ah	04h	Link to Next Tuple is 4 bytes								Link to Next Tuple		
15Ch	07h	I 0	D 0	Configuration Index 7							AT Fixed Disk Secondary I/O 3.3V Configuration	TPCE_INDX
15Eh	00h	M 0	MS 0	IR 0	IO 0	T 0	P 0	P: Power Info type		TPCE_FS		
160h	028h	SanDisk Code								Reserved		
162h	0D3h	SanDisk Code								Reserved		
Attribute Offset	Data	7	6	5	4	3	2	1	0	Content Description	CIS Function	
164h	014h	CISTPL_NO_LINK								Prevent scan of common memory	Tuple Code	
166h	000h	No Bytes following								Link Length is 0 Bytes	Link to Next Tuple	
168h	0FFh	End of Tuple Chain								End of CIS	Tuple Code	

a. Legacy CompactFlash products may report "SunDisk" as the ASCII manufacture string.

Appendix A. Ordering Information

SKU	Capacity	Extended Temperature	Commercial Temperature	Removable Device	Fixed Device
SDCFIR-512M-388	512MB	X		X	
SDCFIF-512M-388	512MB	X			X
SDCFCR-512M-388	512MB		X	X	
SDCFCF-512M-388	512MB		X		X
SDCFIR-001G-388	1GB	X		X	
SDCFIF-001G-388	1GB	X			X
SDCFCR-001G-388	1GB		X	X	
SDCFCF-001G-388	1GB		X		X
SDCFIR-002G-388	2GB	X		X	
SDCFIF-002G-388	2GB	X			X
SDCFCR-002G-388	2GB		X	X	
SDCFCF-002G-388	2GB		X		X
SDCFIR-004G-388	4GB	X		X	
SDCFIF-004G-388	4GB	X			X
SDCFCR-004G-388	4GB		X	X	
SDCFCF-004G-388	4GB		X		X
SDCFIR-008G-388	8GB	X		X	
SDCFIF-008G-388	8GB	X			X
SDCFCR-008G-388	8GB		X	X	
SDCFCF-008G-388	8GB		X		X
SDCFIF-0000-388	Mechanical	X			X

1 megabyte (MB) = 1 million bytes; 1 gigabyte (GB) = 1 billion bytes. Some of the listed capacity is used for formatting and other functions, and thus is not available for data storage.

Appendix B. Limited Warranty

I. Warranty Statement

SanDisk warrants its products to be free of any defects in materials or workmanship that would prevent them from functioning properly for one year from the date of purchase. This express warranty is extended by SanDisk Corporation.

II. General Provisions

This warranty sets forth the full extent of SanDisk's responsibilities regarding the SanDisk Card. In satisfaction of its obligations hereunder, SanDisk, at its sole option, will repair, replace or refund the purchase price of the product.

NOTWITHSTANDING ANYTHING ELSE IN THIS LIMITED WARRANTY OR OTHERWISE, THE EXPRESS WARRANTIES AND OBLIGATIONS OF SELLER AS SET FORTH IN THIS LIMITED WARRANTY, ARE IN LIEU OF, AND BUYER EXPRESSLY WAIVES ALL OTHER OBLIGATIONS, GUARANTIES AND WARRANTIES OF ANY KIND, WHETHER EXPRESS OR IMPLIED, INCLUDING WITHOUT LIMITATION, ANY IMPLIED WARRANTY OF MERCHANTABILITY OR FITNESS FOR A PARTICULAR PURPOSE OR INFRINGEMENT, TOGETHER WITH ANY LIABILITY OF SELLER UNDER ANY CONTRACT, NEGLIGENCE, STRICT LIABILITY OR OTHER LEGAL OR EQUITABLE THEORY FOR LOSS OF USE, REVENUE, OR PROFIT OR OTHER INCIDENTAL OR CONSEQUENTIAL DAMAGES, INCLUDING WITHOUT LIMITATION PHYSICAL INJURY OR DEATH, PROPERTY DAMAGE, LOST DATA, OR COSTS OF PROCUREMENT OF SUBSTITUTE GOODS, TECHNOLOGY OR SERVICES.

IN NO EVENT SHALL THE SELLER BE LIABLE FOR DAMAGES IN EXCESS OF THE PURCHASE PRICE OF THE PRODUCT, ARISING OUT OF THE USE OR INABILITY TO USE SUCH PRODUCT, TO THE FULL EXTENT SUCH MAY BE DISCLAIMED BY LAW.

SanDisk's products are not warranted to operate without failure. Accordingly, in any use of products in life support systems or other applications where failure could cause injury or loss of life, the products should only be incorporated in systems designed with appropriate redundancy, fault tolerant or back-up features.

III. What this Warranty Covers

For products found to be defective within five years of purchase, SanDisk will have the option of repairing or replacing the defective product, if the following conditions are met:

- A. A warranty registration card for each defective product was submitted and is on file at SanDisk. If not, a warranty registration card must accompany each returned defective product.

This card is included in each product's original retail package.

- B. The defective product is returned to SanDisk for failure analysis as soon as possible after the failure occurs.
- C. An incident card filled out by the user, explaining the conditions of usage and the nature of the failure, accompanies each returned defective product.
- D. No evidence is found of abuse or operation of products not in accordance with the published specifications, or of exceeding storage or maximum ratings or operating conditions.

All failing products returned to SanDisk under the provisions of this limited warranty shall be tested to the product's functional and performance specifications.

Upon confirmation of failure, each product will be analyzed, by whatever means necessary, to determine the root cause of failure. If the root cause of failure is found to be not covered by the above provisions, then the product will be returned to the customer with a report indicating why the failure was not covered under the warranty.

This warranty does not cover defects, malfunctions, performance failures or damages to the unit resulting from use in other than its normal and customary manner, misuse, accident or neglect; or improper alterations or repairs.

SanDisk reserves the right to repair or replace, at its discretion, any product returned by its customers, even if such product is not covered under warranty, but is under no obligation to do so.

SanDisk may, at its discretion, ship repaired or rebuilt products identified in the same way as new products, provided such cards meet or exceed the same published specifications as new products. Concurrently, SanDisk also reserves the right to market any products, whether new, repaired, or rebuilt, under different specifications and product designations if such products do not meet the original product's specifications.

IV. Receiving Warranty Service

According to SanDisk's warranty procedure, defective product should be returned only with prior authorization from SanDisk Corporation. Please contact SanDisk's OEM Support Department at 866-436-6073 with the following information: product model number and description, serial numbers, nature of defect, conditions of use, proof of purchase and purchase date. If approved, SanDisk will issue a Return Material Authorization or Product Repair Authorization number and provide a shipping address where the defective product can be returned.

V. State Law Rights

SOME STATES DO NOT ALLOW THE EXCLUSION OR LIMITATION OF INCIDENTAL OR CONSEQUENTIAL DAMAGES, OR LIMITATION ON HOW LONG AN IMPLIED WARRANTY LASTS, SO THE ABOVE LIMITATIONS OR EXCLUSIONS MAY NOT APPLY TO YOU.

This warranty gives you specific rights and you may also have other rights that vary from state to state.

Appendix C. Disclaimer of Liability

SanDisk Corporation Policy

SanDisk Corporation general policy does not recommend the use of its products in life support applications wherein a failure or malfunction of the product may directly threaten life or injury.

Accordingly, in any use of products in life support systems or other applications where failure could cause damage, injury or loss of life, the products should only be incorporated in systems designed with appropriate redundancy, fault tolerant or back-up features.

SanDisk shall not be liable for any loss, injury or damage caused by use of the Products in any of the following applications:

- Special applications such as military related equipment, nuclear reactor control, and aerospace
- Control devices for automotive vehicles, train, ship and traffic equipment
- Safety system for disaster prevention and crime prevention
- Medical-related equipment including medical measurement device